

BALL SPLINE

The NB ball spline is a linear motion mechanism utilizing the rotational motion of ball elements. It can be used in a wide variety of applications including robotics and transport type equipment.

STRUCTURE AND ADVANTAGES

The NB ball spline consists of a spline shaft with raceway grooves and a spline nut. The spline nut consists of an outer cylinder (main body), retainer, side rings, and ball elements. Designed and manufactured to achieve a reliably smooth motion.

High Load Capacity and Long Travel Life:

The raceway grooves are machined to a radius close to that of the ball elements. The large ball contact surface results in high load capacity and long travel life.

Wide Variety of Configurations:

A total of 16 shafts with diameters ranging from 4mm to 100mm are available. Seven different types of nuts are available: cylindrical types (SSP/SSPM), flange types (SSPF/SSPT), and block types (SPA/SPA-W/SSPB). They can be specified to suit various applications.

Transmission of Torque:

NB ball splines can sustain loads in several directions simultaneously. They can be used as a single shaft system and can transmit (or resist) torque.

Zero Clearance in Rotational Direction:

The contact angle of the ball elements is such that a pre-load can be applied that allows zero clearance in the rotational direction, resulting in increased rigidity.

Ease of Additional Custom Machining:

Since a round shaft with raceway grooves is used, NB ball spline shafts can be machined easily to customized specifications.

High-Speed Motion and High-Speed Rotation:

The outer cylinder is compact and well balanced, resulting in good performance at high speed.

Figure B-1 Basic Structure of NB Ball Spline

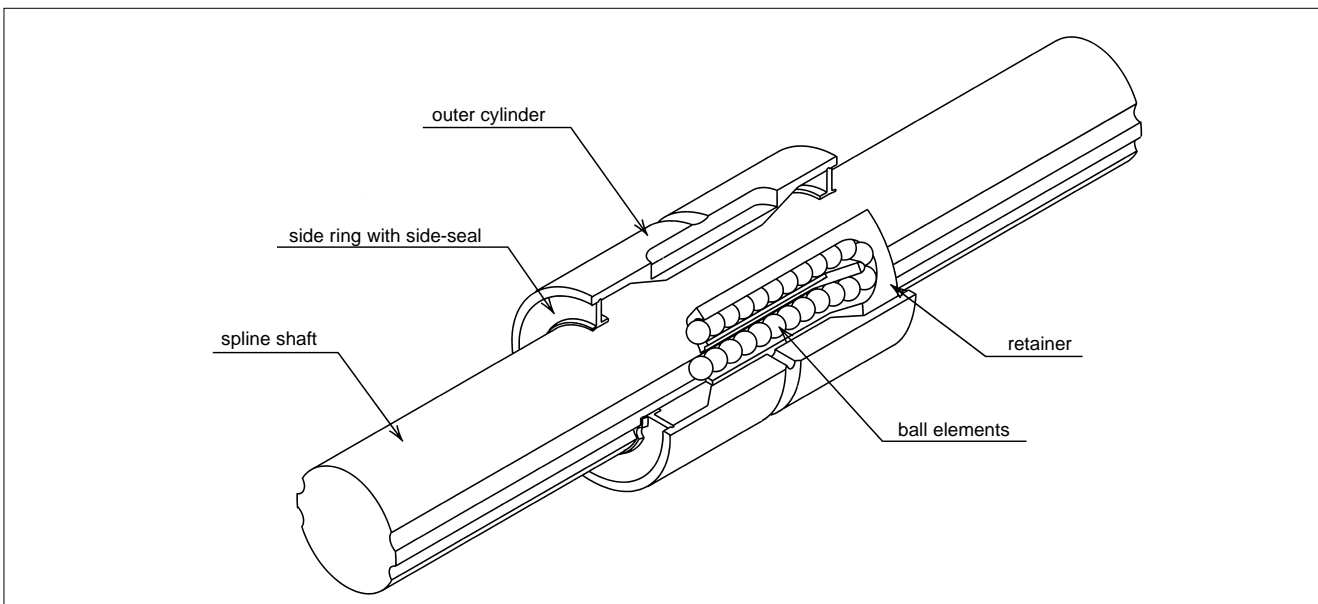

TYPE

TYPES OF SPLINE NUT:

A wide variety of spline nut designs are available and all spline nuts come with a side-seal as a standard feature.

Table B-1 Types of Spline Nut

type of nut		shape and advantage		page number for dimension table
cylindrical type	SSP		<ul style="list-style-type: none"> • cylindrical spline nut with key groove • with special key • nominal diameter: 4mm-100mm 	P.B-16
	SSPM		<ul style="list-style-type: none"> • cylindrical spline nut without key groove • with two lock plates for fixing • nominal diameter: 6mm-10mm 	P.B-18
flange type	SSPF		<ul style="list-style-type: none"> • spline nut with flange • nominal diameter: 6mm-60mm 	P.B-20
	SSPT		<ul style="list-style-type: none"> • spline nut with a two side cut flange • nominal diameter: 6mm-10mm 	P.B-22



Table B-2 Types of Spline Nut

type of nut		shape and advantage		page number for dimension table
block type	SPA		<ul style="list-style-type: none"> • aluminum housing • lightweight and compact • with keyless spline • nominal diameter: 6mm-10mm 	P.B-24
	SPA-W		<ul style="list-style-type: none"> • aluminum housing • can sustain high moment loading • with two keyless splines • with grease fitting • nominal diameter: 6mm-10mm 	P.B-26
	SSPB		<ul style="list-style-type: none"> • cast block • spline grooves are machined directly on main body • high rigidity • with grease fitting • nominal diameter: 20mm-40mm 	P.B-28

TYPES OF SPLINE SHAFT:

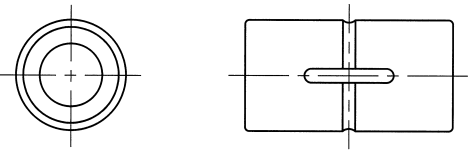
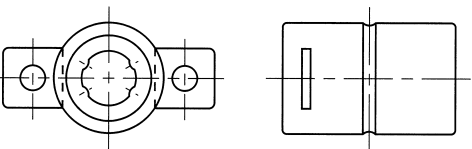
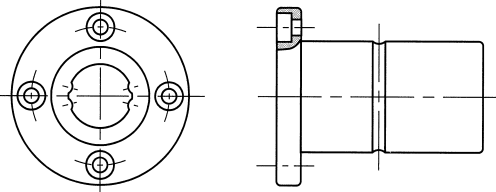
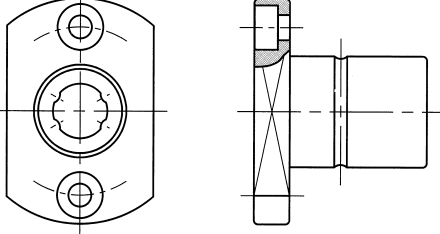
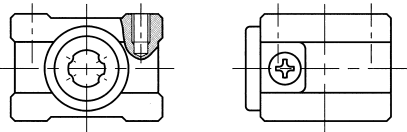
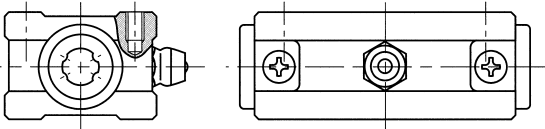
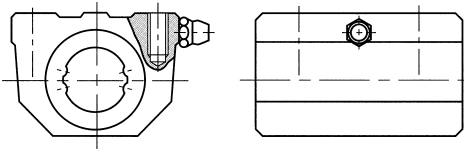
Depending on the application requirements, either a fully machine ground spline shaft or a commercial grade spline shaft can be specified.

Table B-3 Types of Spline Shaft

type of spline shaft	shape and advantage
ground spline shaft	 <ul style="list-style-type: none"> • precision-ground and precision machined surface finish • high precision • possible to machine ends of spline shaft and surface finish • nominal diameter: 4mm-100mm
standard spline shaft	 <ul style="list-style-type: none"> • standard dimension and shape • accuracy grade: high grade • short lead time • nominal diameter: 4mm-60mm (Refer to page B-30)
commercial shaft (non-ground)	 <ul style="list-style-type: none"> • for general industrial use • with special finished raceway surface • low cost • possible to machine end of shaft and surface finish • nominal diameter: 20mm-50mm • maximum length: 5000mm (Refer to page B-31)

ACCURACY

The NB ball spline is measured for accuracy at points shown in Figure B-2 and categorized as either high-grade or precision-grade (P). Contact NB for accuracy information on the commercial type ball spline.

Table B-4 Tolerance of Spline Shaft and groove torsion

type of shaft	ground shaft	
	high	precision (P)
tolerance	13 $\mu\text{m}/100\text{mm}$	6 $\mu\text{m}/100\text{mm}$

Figure B-2 Accuracy Measurement Points

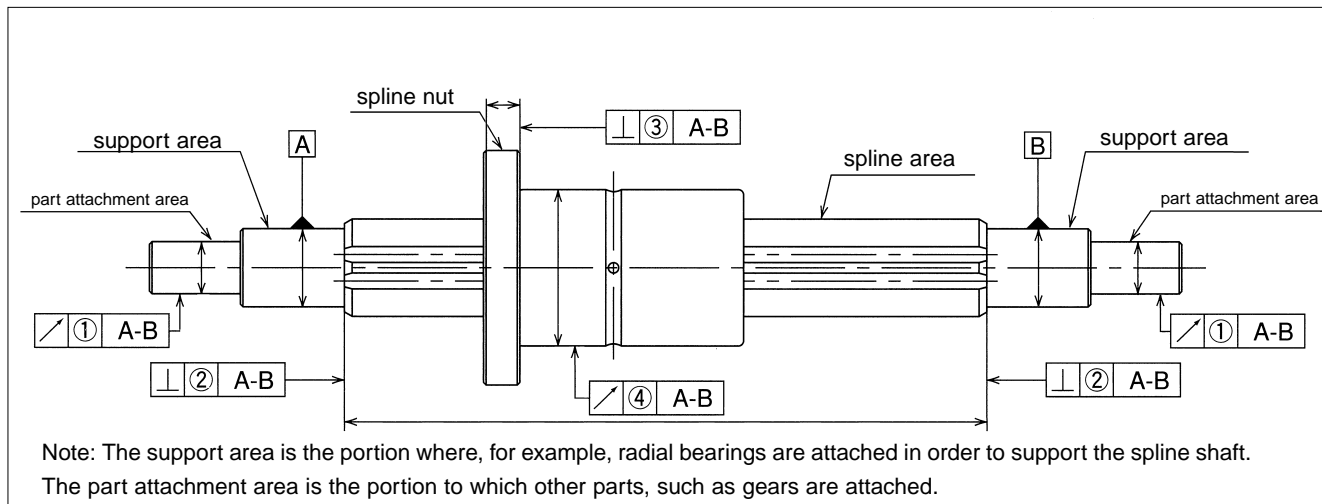

Table B-5 Maximum Tolerance for Spline Support Area

unit/ μm

part number	radial run-out at part attachment area ①		perpendicularity of spline-shaft end surface ②		perpendicularity of flange attachment surface ③	
	high-grade	precision-grade	high-grade	precision-grade	high-grade	precision-grade
SSP 4					—	—
SSP 6	14	8	9	6	11	8
SSP 8						
SSP 10	17	10				
SSP 13A	19	12	11	8	13	9
SSP 16A						
SSP 20						
SSP 25	22	13	13	9	16	11
SSP 30						
SSP 40	25	15	16	11	19	13
SSP 50						
SSP 60	29	17	19	13	22	15
SSP 80 · 80L						
SSP100 · 100L	34	20	22	15	—	—

Table B-6 Maximum Radial Run-Out of Spline Nut Outer Surface Relative to Spline Shaft Support Area④

 unit/ μm

total length of spline shaft (mm)		part number													
		SSP4 SSP6 SSP8		SSP10		SSP13A SSP16A		SSP20 SSP25 SSP30		SSP40 SSP50		SSP60 SSP80 SSP80L		SSP100 SSP100L	
greater than	or less	high-grade	precision grade	high-grade	precision grade	high-grade	precision grade	high-grade	precision grade	high-grade	precision grade	high-grade	precision grade	high-grade	precision grade
—	200	46	26	36	20	34	18	32	18	32	16	30	16	30	16
200	315	89	57	54	32	45	25	39	21	36	19	34	17	32	17
315	400	126*	82*	68	41	53	31	44	25	39	21	36	19	34	17
400	500	163*	108*	82	51	62	38	50	29	43	24	38	21	35	19
500	630	—	—	102	65	75	46	57	34	47	27	41	23	37	20
630	800	—	—	—	—	—	—	68	42	54	32	45	26	40	22
800	1,000	—	—	—	—	—	—	83	52	63	38	51	30	43	24
1,000	1,250	—	—	—	—	—	—	102	65	76	47	59	35	48	28
1,250	1,600	—	—	—	—	—	—	130	85	93	59	70*	43*	55	33
1,600	2,000	—	—	—	—	—	—	171	116	118	77	86*	54*	—	—

*SSP4 maximum fabrication length: 300mm; SSP6 maximum fabrication length: 400mm; SSP80, 80L, 100 and 100L maximum fabrication length: 1500mm

**For lengths exceeding 2000mm, contact NB.

PRE-LOAD AND CLEARANCE IN ROTATIONAL DIRECTION

Both the clearance and pre-load are expressed in terms of clearance in the rotational direction. The pre-load is categorized into three different levels : standard, light (T1), and medium (T2). A pre-load cannot be specified when using the commercial grade spline shaft.

 Table B-7 Pre-Load and Clearance in Rotational Direction unit/ μm

part number	standard	light (T1)	medium (T2)
SSP 4	-2~+1	-6~-2	—
SSP 6			
SSP 8			
SSP 10	-3~+1	-9~-3	-13~-7
SSP 13A SSP 16A			
SSP 20	-4~+2	-12~-4	-20~-12
SSP 25			
SSP 30			
SSP 40	-6~+3	-18~-6	-30~-18
SSP 50			
SSP 60			
SSP 80(L)			
SSP100(L)	-8~+4	-24~-8	-40~-24

Table B-8 Operating Condition and Pre-Load

pre-load	pre-load symbol	operating condition
standard	—	Minute vibration is applied. A precise motion is required. A torque in a given direction is applied.
light	T1	Slight vibration is applied. Slight torsional load is applied. Cyclic torque is applied
medium	T2	Shock/vibration is applied. Over-hang load is applied. Torsional load is applied.

LIFE CALCULATION

Because ball elements are used as the rolling elements in ball splines, the following equations are used to calculate the life of ball spline systems.

For radial load

$$L = \left(\frac{f_c}{f_w} \cdot \frac{C}{P} \right)^3 \cdot 50$$

For torsional load

$$L = \left(\frac{f_c}{f_w} \cdot \frac{C_T}{T} \right)^3 \cdot 50$$

L : travel life (km)

f_c : contact coefficient

f_w : Load coefficient

C : basic dynamic load rating(N)

P : load(N) C_T : basic dynamic torque rating(N-m)

T : torque(N-m)

** The rated load for the commercial spline shaft is approximately 70% of the standard ball spline shaft.

Figure B-3 Radial Loading and Torque Loading

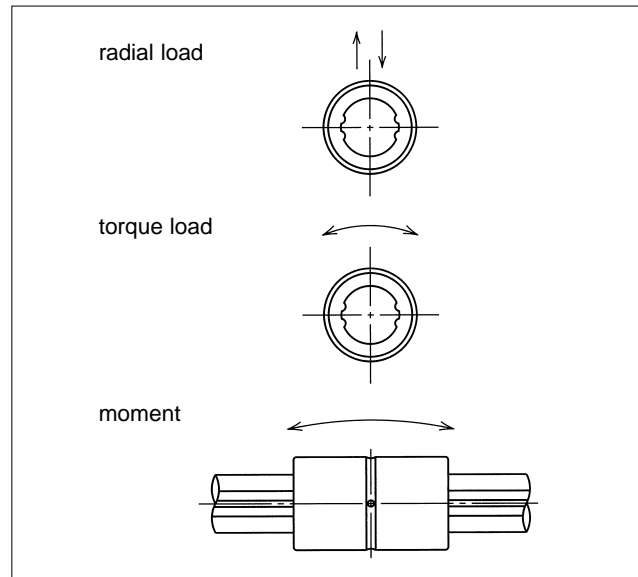

OPERATING CONDITIONS

The performance of a ball spline system is affected by the operating condition and environment of the application. The operating conditions should therefore be carefully taken into consideration.

Dust Prevention:

The introduction of foreign particles and dust may affect the motion characteristics and shorten the life of a ball spline. In a typical operating environment, seals work well. However, they may not prevent the entry of foreign particles in a hostile environment. When used in such an environment, the ball spline should be protected using bellows and protective covers.

Operating Temperature:

The ball retainers used in ball spline nuts are made of resin, so the operating temperature should never exceed 80°C.

Figure B-4 Examples of Dust Prevention Methods

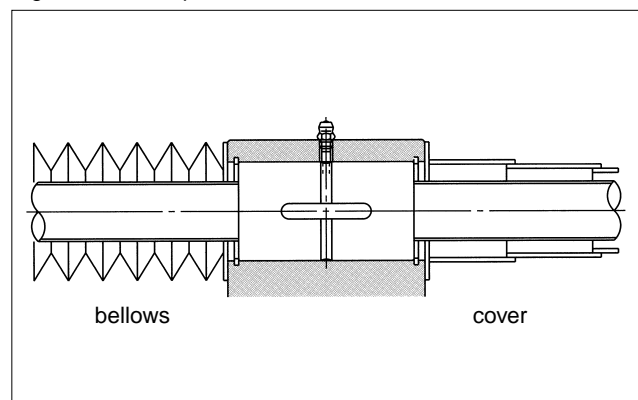

Excessive Moment:

The allowable load for ball splines is high, and they can also sustain high moment load. However, when the load becomes excessive, the load applied to the raceway grooves becomes unbalanced and stable motion may not be achieved. When accuracy is required, the application of excessive moment should be prevented by using two or more spline nuts.

LUBRICATION

Both ends of the spline nut have a side-seal as a standard feature. For the fully ground spline shaft, the side-seals are positioned against the spline shaft so as to prevent the lubricant from leaking out of the spline nut.

Lithium soap grease is applied to NB ball spline nuts before shipping, so there is no need to apply lubricant at the time of installation. However, a small amount of lubricant may be lost during operation, so the lubricant needs to be replenished periodically.

Figure B-5 Example of Lubrication Mechanism

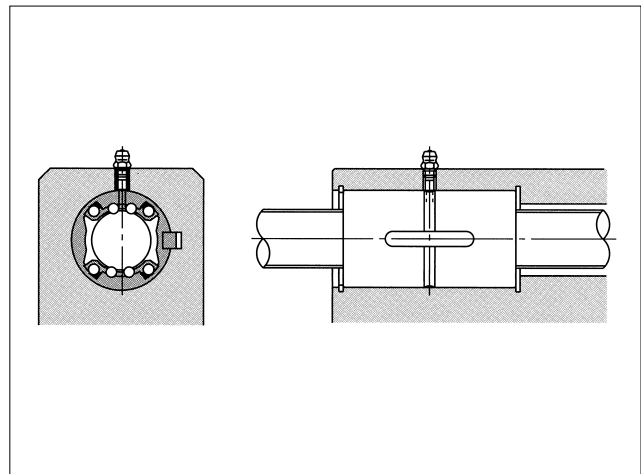

SPECIAL REQUIREMENTS

NB will fabricate custom shafts, spline nut, surface finish, etc. to meet customer requirements.

For hollow spline shafts, recommended standard inner diameters are listed in Table B-9. Contact NB for details.

Figure B-6 Example of End-Machining

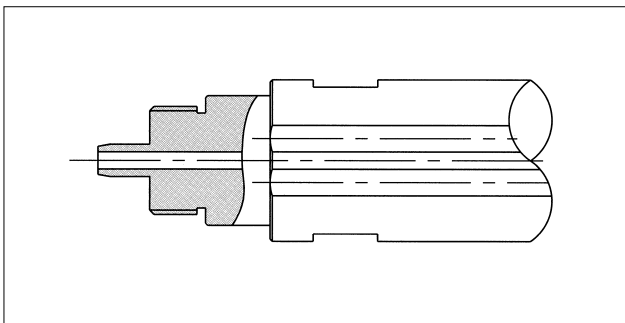
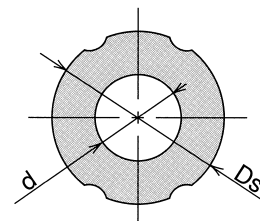

Table B-9 Recommended Inner Diameter for Hollow Spline Shaft

part number	shaft diameter	inner diameter	cross-sectional coefficient	second moment of inertia
	Ds mm	d mm	Z mm ³	I mm ⁴
SSP 4	4	1.5	5.7	11
SSP 6	6	2	19.4	58
SSP 8	8	3	46.5	186
SSP 10	10	4	89.6	448
SSP 13A	13	6	193	1,260
SSP 16A	16	8	348	2,780



MOUNTING

Fit:

A transition fit between an SSP/SSPM-type spline nut and its housing bore is used to minimize the clearance. If high accuracy is not required, then a clearance fit clearance is used.

For the SSP/SSPM type spline nuts, if only a light load is to be applied, a hole slightly larger than the outer diameter of the nut will suffice.

Insertion of Spline Nut:

When inserting a spline nut into the housing, use a jig, example as shown in Figure B-7. Carefully insert the nut so as not to hit the side ring and side-seal.

Table B-11 Recommended Jig Dimensions unit/mm

part number	D	d	part number	D	d
SSP4	9.5	3.5	SSP30	44.5	25
SSP6	13.5	5	SSP40	59.5	33
SSP8	15.5	7	SSP50	74	41
SSP10	20.5	8.5	SSP60	89	50
SSP13A	23.5	12	SSP80	119	74
SSP16A	30.5	14.5	SSP80L		
SSP20	31.5	16.5	SSP100	149	92
SSP25	36.5	20.5	SSP100L		

Insertion of Spline Shaft:

Insertion of Spline Shaft: When inserting the spline shaft into the spline nut, ensure that the ball elements do not drop out. This is accomplished by aligning the raceway grooves of the shaft with the rows of ball elements in the nut. Then simply insert the spline shaft through the spline nut.

Table B-10 Fit for the Spline Nut

type of spline nut	clearance fit	transition fit
SSP	H7	J6
SSPM		

Figure B-7 Insertion of Spline Nute into Housing

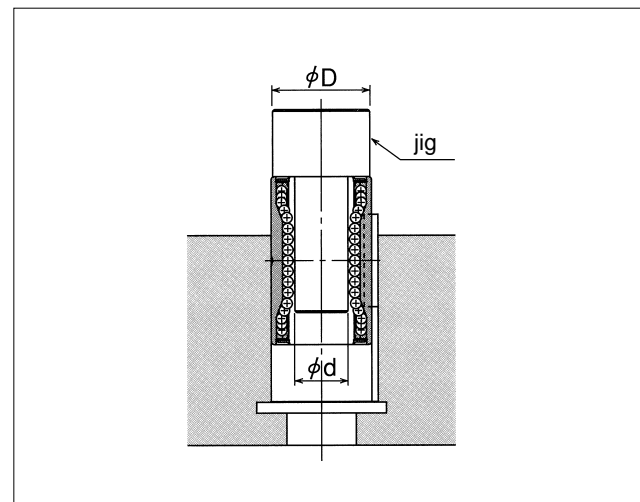

Mounting of SSP Type Spline:

Example methods for mounting the SSP type spline is shown in Figures B-8 and B-9.

Figure B-8 Using a Retaining Ring

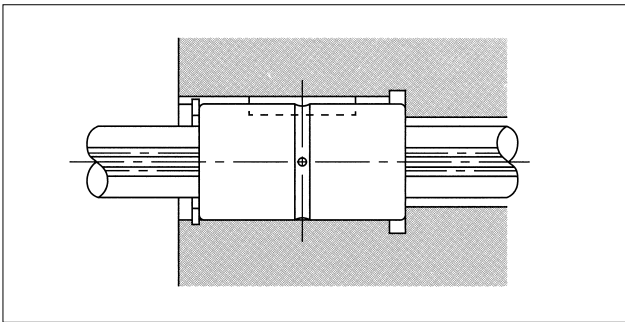
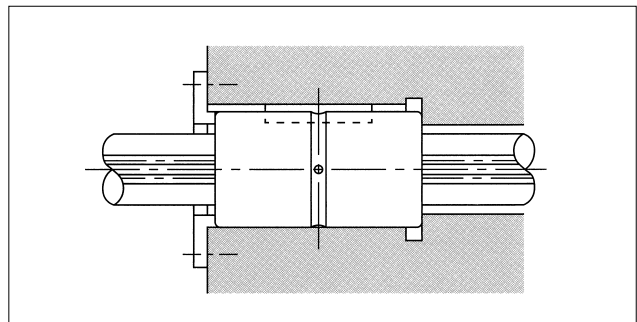

Figure B-9 Using a Push Plate



Key:

The SSP type spline comes with a key, as shown in Figure B-10.

Figure B-10 Key for SSP Type Spline

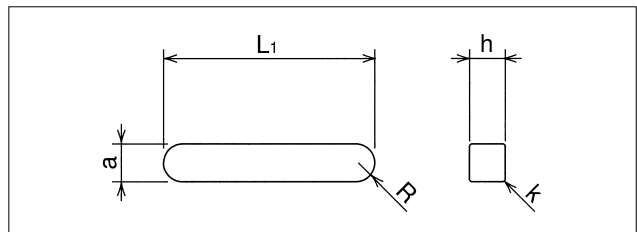

Table B-12 Major Dimensions of Key (SSP Type)

part number	a		h		L ₁	R	k
	mm	tolerance μm	mm	tolerance μm			
SSP 4	2	+16 + 6	2	0 -25	6	1	0.2
SSP 6	2.5		2.5		10.5	1.25	
SSP 8	2.5		2.5		10.5	1.25	
SSP 10	3		3		13	1.5	
SSP 13A	3		3		15	1.5	
SSP 16A	3.5	+24 +12	3.5	0 -30	17.5	1.75	0.3
SSP 20	4		4		26	2	
SSP 25	5		5		33	2.5	
SSP 30	7	+30 +15	7	0 -36	41	3.5	0.5
SSP 40	10		8		55	5	
SSP 50	15	+36 +18	10	0/-43 0 -36	60	7.5	0.8
SSP 60	18		11		68	9	
SSP 80	16		10		76	8	
SSP 80L		110					
SSP100	20	+43 +22	13	0 -43	110	10	
SSP100L					160		

Mounting of SSPM Type Spline:

Example methods for installing the SSPM spline is shown in Figures B-11 to B-14.

Figure B-11 Using an F Type Lock Plate

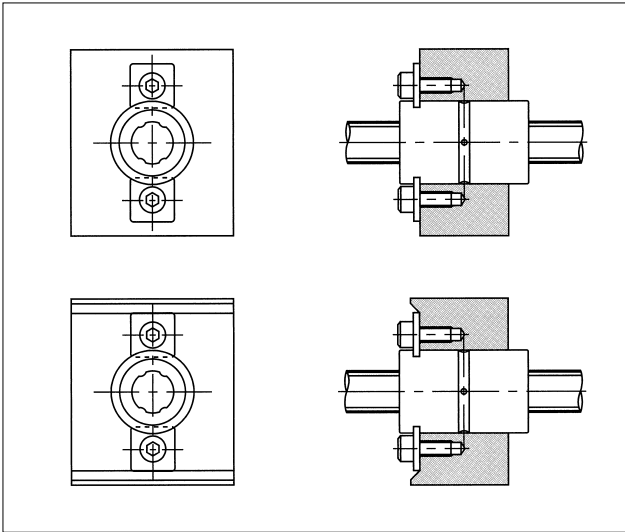

Figure B-12 Using an LP Type Lock Plate

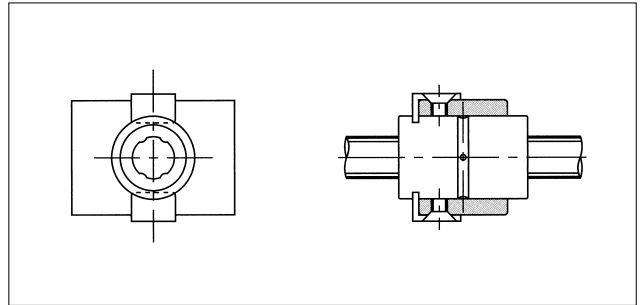

Figure B-13 Using a Special Lock Plate (1)

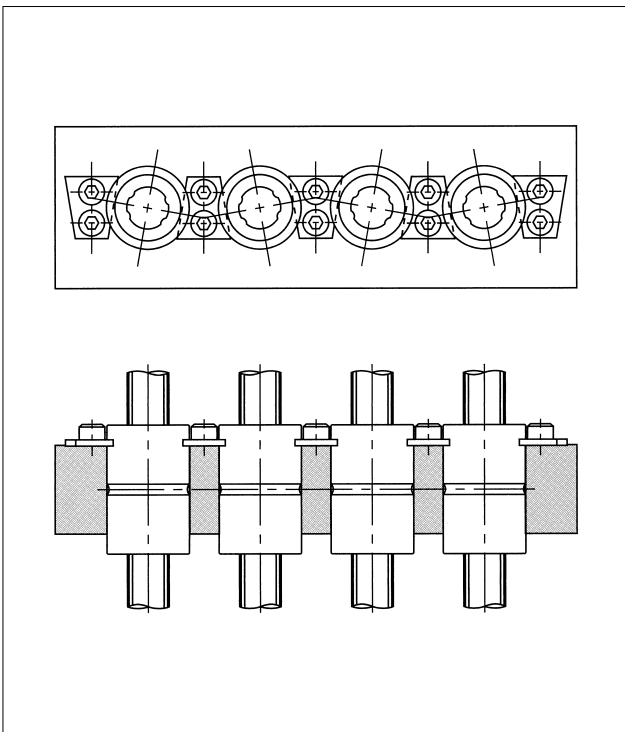
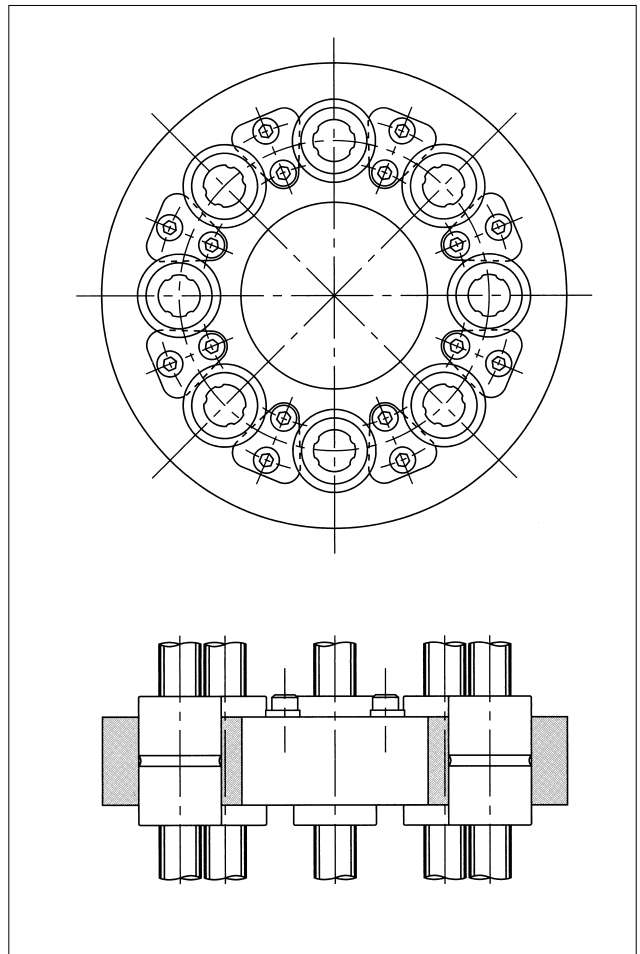

Figure B-14 Using a Special Lock Plate (2)



F Type Lock Plate (Standard Part):

The lock plate shown in Figure B-15 is provided with the SSPM spline.

Material: SUS304CSP

Figure B-15 F Type Lock Plate

Table B-13 F Type Lock Plate

part number	K mm	G mm	t mm	R mm	applicable spline nut
FP 6	6.8	2.9	1.0	0.5	SSPM 6
FP 8	8.5	3.5	1.2	0.5	SSPM 8
FP10	8.5	3.5	1.2	0.5	SSPM10

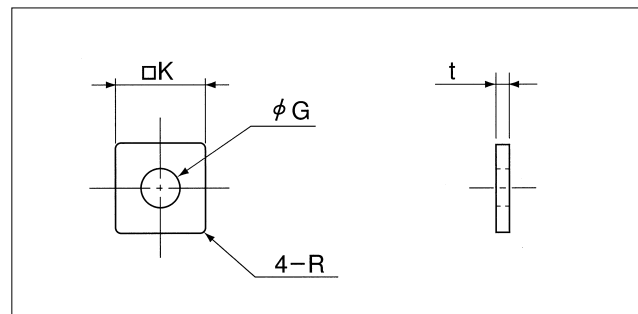

LP Type Lock Plate (Purchased Separately):

An LP type lock plate is also available for use with the SSPM spline.

Material: SUS304CSP

Figure B-16 LP Type Lock Plate

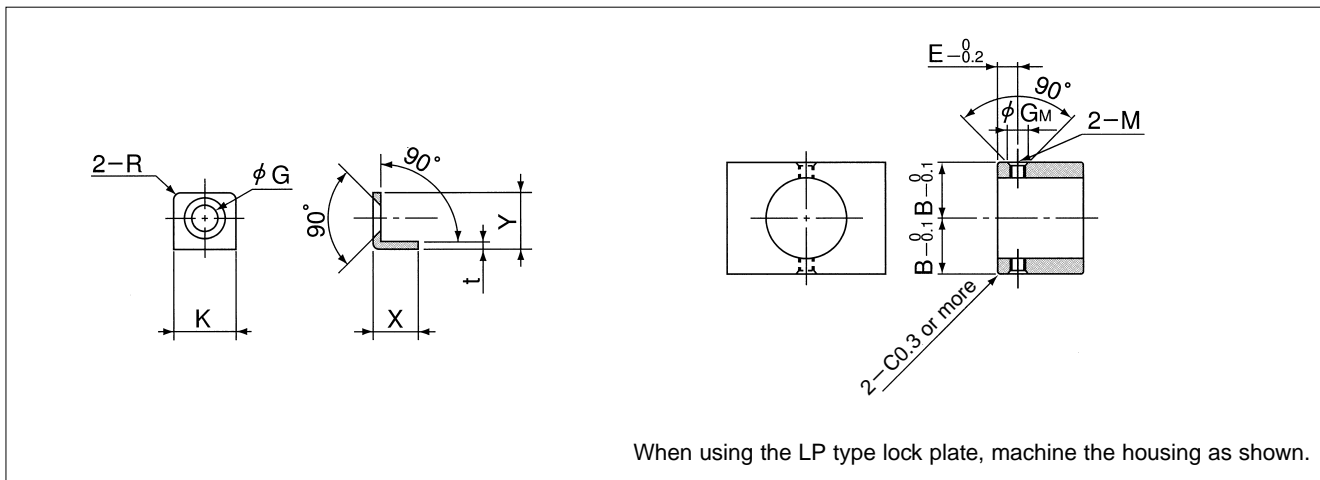

When using the LP type lock plate, machine the housing as shown.

Table B-14 LP Type Lock Plate

part number	lock plate major dimensions						machined housing dimensions				applicable spline nut
	K mm	G mm	t mm	R mm	X mm	Y mm	B mm	E mm	G _M mm	M	
LP 6	8.6	4.3	1.0	1	5.85	7.8	11.1	3.3	3.5	M2.5	SSPM 6
LP 8	9.15	5.0	1.2	1	6.45	9.2	12.3	4.0	4.0	M3	SSPM 8
LP10	9.15	5.0	1.2	1	6.45	9.2	14.8	4.0	4.0	M3	SSPM10

Mounting of SSPF Type Spline:

Example methods for mounting the SSPF spline are shown in Figure B-17.

Figure B-17 Example Methods for mounting SSPF Type Spline

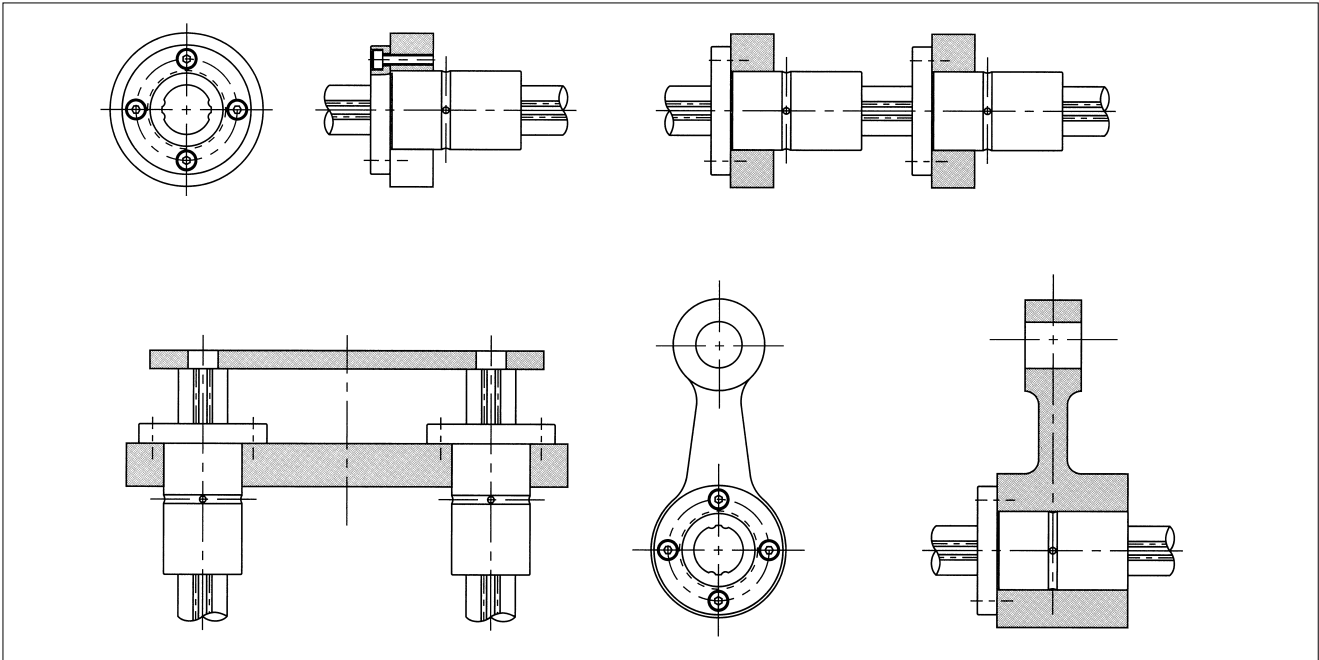

Mounting of SSPT Spline:

Example methods for mounting the SSPT spline are shown in Figure B-18.

Figure B-18 Example Methods for mounting SSPT Type Spline

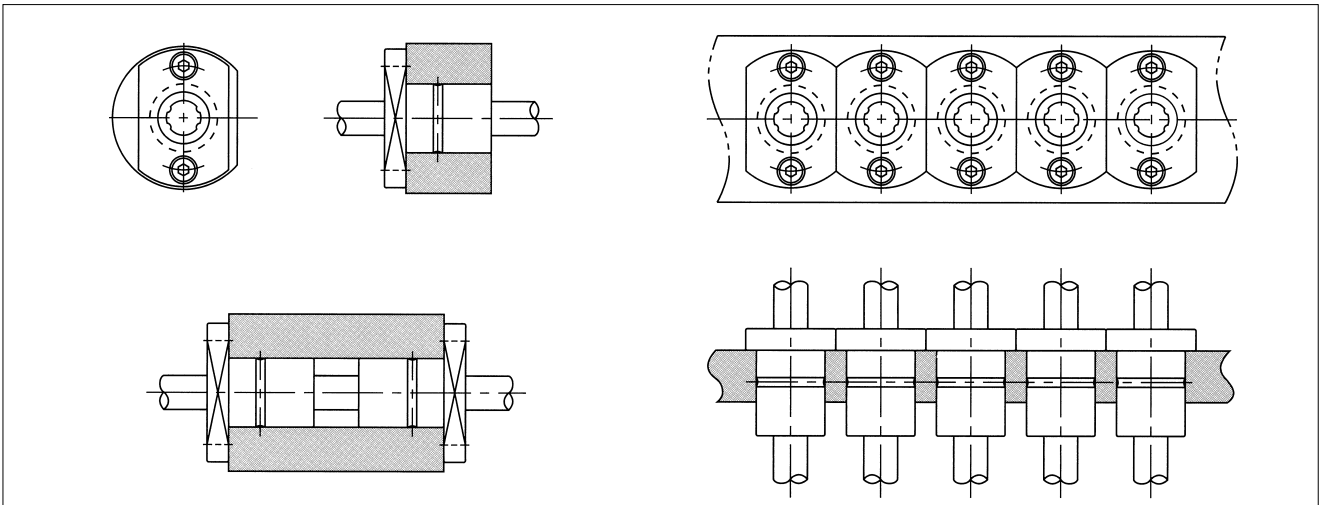

Mounting of Block Type Spline:

Example methods for mounting the block spline are shown in Figure B-19.

Figure B-19 Example Methods for mounting Block Type Spline

