

SLIDE WAY

The NB slide way is a non-recirculating linear motion bearing utilizing precision rollers. It is used primarily in optical and measurement equipment where high precision movement is required.

STRUCTURE AND ADVANTAGES

The NB slide way consists of precision ground track bases and caged rollers. Precision rollers are used as the rotating element. Since they do not recirculate, there is less frictional resistance fluctuation. Additionally, there is little or no difference between the static and dynamic frictional resistances.

Suitable for Minute Motion:

Because the frictional resistance is extremely small and there is little or no difference between the static and dynamic frictional resistances, the NB slide way is well suited for minute motion. It can follow minute motion accurately, resulting in highly accurate linear movement.

Low-Speed Stability:

Since the frictional resistance fluctuation is small even under low-load conditions, stable motion is obtained from low to high speeds.

High Rigidity and High Load Capacity:

Since the rollers provide a larger contact area compared with ball elements, there is less elastic deformation. Additionally, since the rollers do not recirculate, the effective number of rotating elements is large, resulting in high rigidity and high load capacity.

Low Noise:

The use of a roller cage prevents noise from being generated by contact between the rotating elements, resulting in quiet operation.

All Stainless Type Available:

The anti-corrosion SVS/SVWS slide ways have all stainless-steel components, making them ideal for use in clean room applications.

Figure H-1 Slide Way Structure

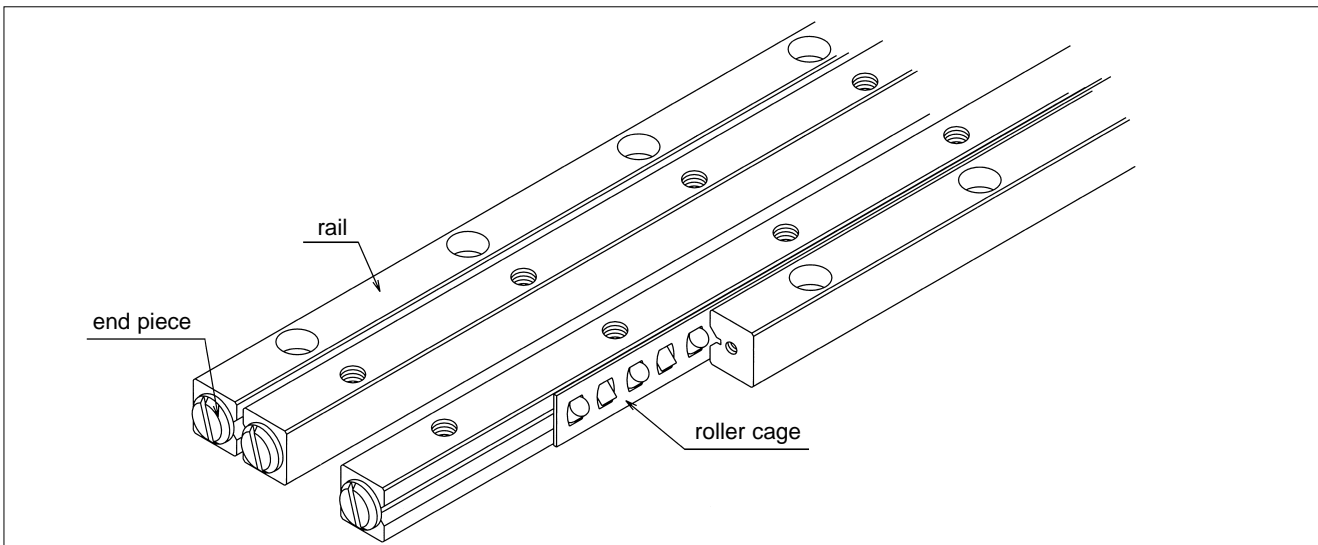

TYPE

SV Type

P.H-8

The SV type slide way consists of two R type roller cages, which have precision rollers in a cross arrangement and four rails having V-shaped raceway surfaces. The all stainless-steel optional feature makes it suitable for use in corrosive environments.

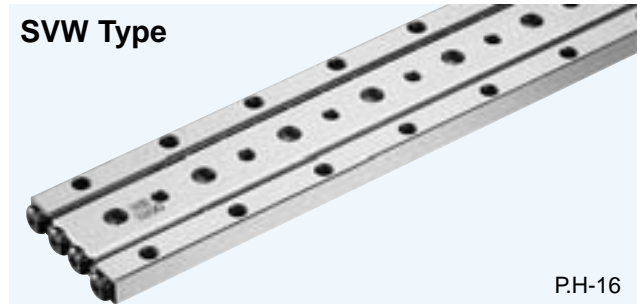
SVW Type

P.H-16

The SVW type slide way consists of two R type roller cages, two SV-type rails, and one W type rail with V-shaped grooves on both sides. The use of a W-type rail results in a compact design. The SVWS type is also available with all stainless steel components.

ACCURACY AND RATED LIFE

Accuracy:

The accuracy of a slide way is measured along its entire length, as illustrated in Figure H-3, and expressed in terms of parallelism. It is categorized into three levels: high grade (no suffix), precision grade (P), and high-precision grade (UP).

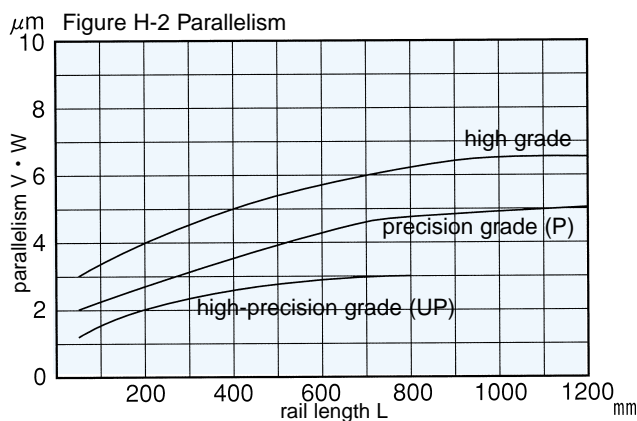
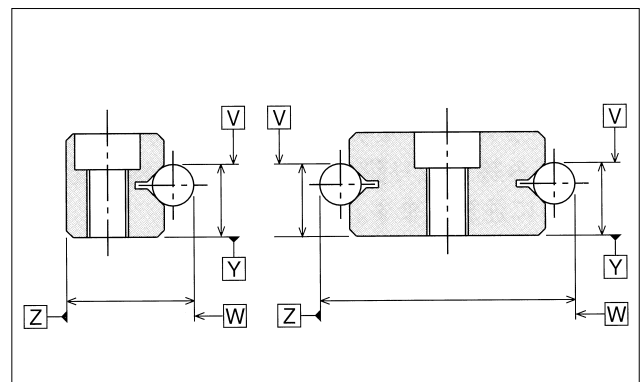

Figure H-3 Accuracy Measurement Method



High-precision grade is available for size 1-9

Rated Life:

The life of a slide way is calculated using the following equation:

Travel life:

$$L = \left(\frac{f_T}{f_W} \cdot \frac{C}{P} \right)^{10/3} \cdot 50$$

L : travel life (km) f_T : temperature coefficient
 f_W : load coefficient C : basic dynamic rated load (N)
 P : load (N)

※ Refer to page Eng. 5 for coefficients.

Life time:

$$L_H = \frac{L \cdot 10^3}{2 \cdot \ell \cdot s \cdot n_1 \cdot 60}$$

L_H : life time (hr) ℓ : stroke length (m)
 n_1 : number of strokes per minute (cpm)

MOUNTING

Example:

Figure H-4 SV Type Slide Way

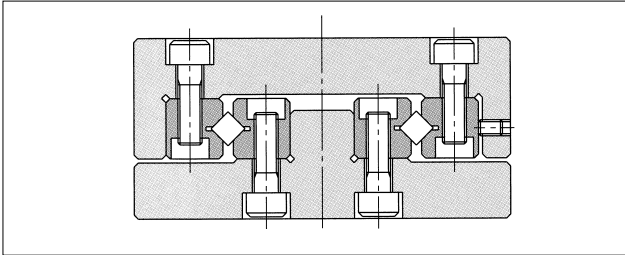
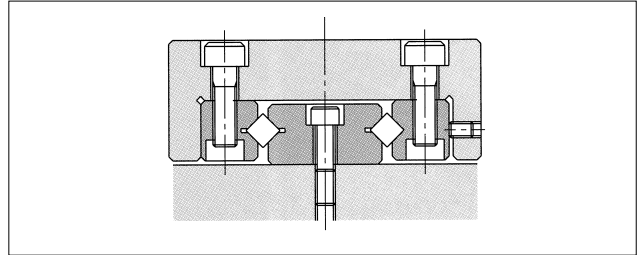

Figure H-5 SVW Type Slide Way



Accuracy:

The accuracy of the mounting surface must be equal to or better than that of the slide way to ensure good performance.

- Parallelism of surface 1 relative to surface A
- Perpendicularity of surface 2 relative to surface A
- Parallelism of surface 3 relative to surface B
- Perpendicularity of surface 4 relative to surface B
- Parallelism of surface 2 relative to surface C
- Parallelism of surface 4 relative to surface C

Figure H-6 Accuracy of Mounting Surfaces

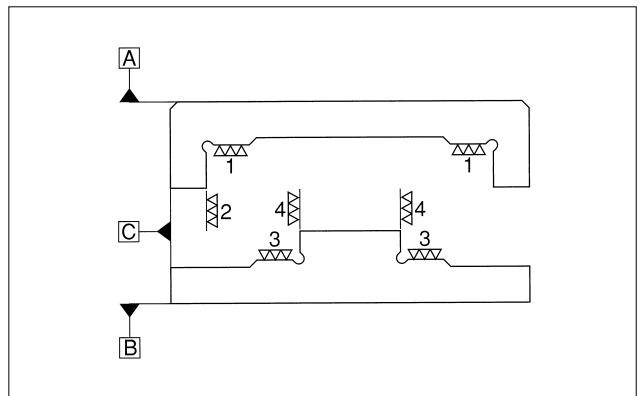

Procedure (refer to Figures H-7 and -8):

- (1) Remove burrs, dirt, dust, etc. from mounting surfaces to prevent contamination during assembly.
- (2) Apply low-viscosity oil to contact surfaces. Attach rail ①-③ by tightening bolts to specified torque values (Table H-2, Figure H-7a).
- (3) Temporarily attach adjustable side of rail ④ (Figure H-7b).
- (4) Remove one end-piece. Carefully insert roller cages between rails (Figure H-7c).
- (5) Re-attach end-pieces.

Figure H-7 Installation Method (1)

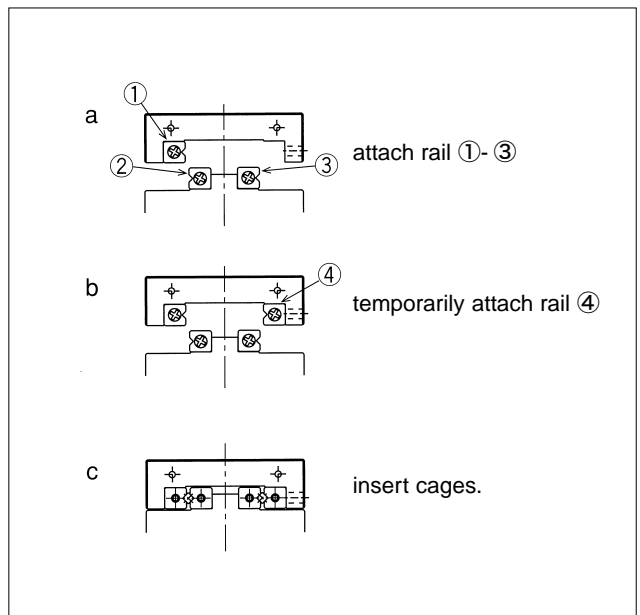

(6) Move table slowly to the right and left (in the direction of the stroke) to position roller cage at the center of the rail.

(7) Set indicators at the center and the side (reference surface) of the table (Figure H-8d).

(8) Move table to one of the stroke ends. Lightly tighten adjustment screw on roller cage (Figure H-8e).

(9) Move table to the other stroke end. Similarly lightly tighten adjustment screw on roller cage (Figure H-8f).

(10) Move table to the center and lightly tighten center adjustment screw (Figure H-8g).

(11) Repeat steps (8) ~ (10) until there is no clearance around the table. When there is no clearance, the indicator will show a minimum fluctuation value when the table is moved to the right and left. Exercise care not to apply an excessive pre-load.

(12) Make final adjustment of pre-load. Repeat steps (8) ~ (10) and tighten the adjustment screws to the torque values listed in Table H-1.

(13) Fix the rail ④. As done for the adjustment screws, tighten the mounting bolts by moving the table.

Figure H-8 Installation Method (2)

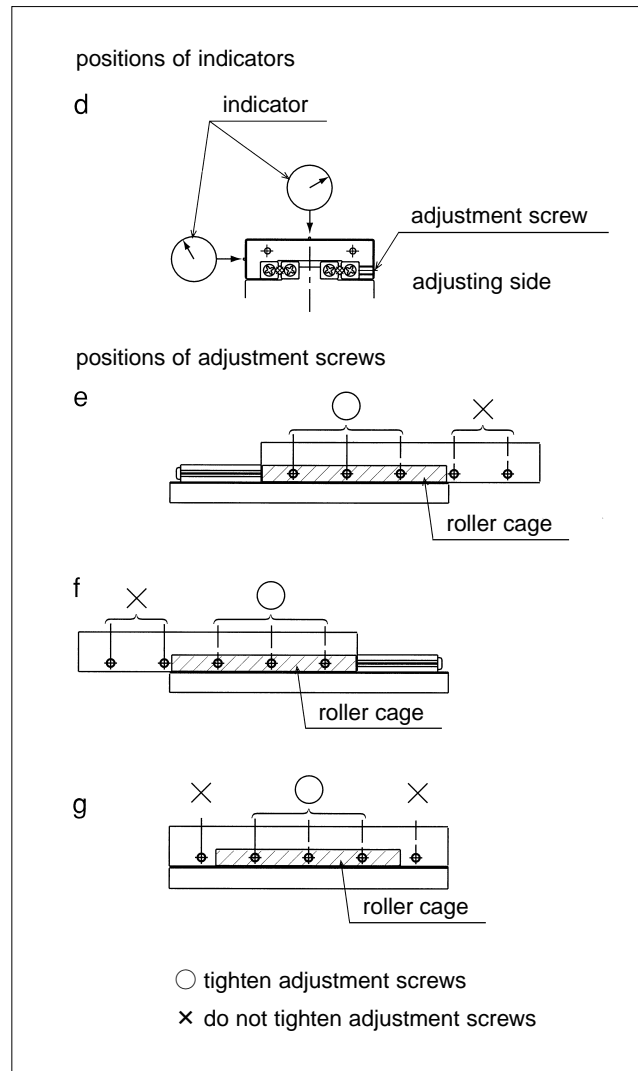

Table H-1 Recommended Torque for Adjustment Screw Unit/N·m

Part Number	Size	Torque
SV1	M2	0.008
SV2	M3	0.012
SV3	M4	0.05
SV4	M4	0.08
SV6	M5	0.20
SV9	M6	0.40

Table H-2 Recommended Torque for Mounting Bolt Unit/N·m

Part number	Size	Torque
SV1	M2	0.4
SV2	M3	2
SV3	M4	4
SV4	M5	6
SV6	M6	8
SV9	M8	12

SPECIAL BOLT (BT type)

BT type special bolts should be used when using the clearance holes to install a slide way.

Figure H-9 BT type Special Bolt

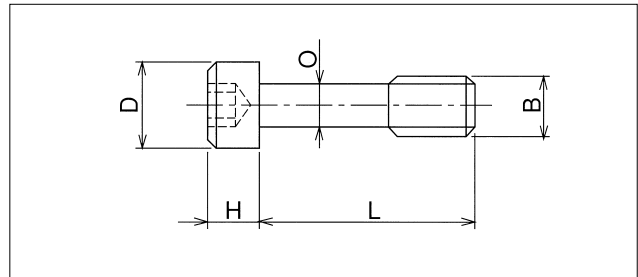

Table H-3 BT type Special Bolt Specifications

Part number	B	O	D	H	L	Applicable tracking base
		mm	mm	mm	mm	
BT 3	M 3	2.3	5	3	12	SV 3
BT 4	M 4	3.1	5.8	4	15	SV 4
BT 6	M 5	3.9	8	5	20	SV 6
BT 9	M 6	4.6	8.5	6	30	SV 9
BT12	M 8	6.25	11.3	8	40	SV12

LUBRICATION AND DUST PREVENTION

Lubrication:

NB slide ways are lubricated using lithium soap grease prior to shipment, so they can be used immediately. Periodic application of a similar type grease is recommended depending on the operating conditions.

NB also provides “K-Grease” for low dust generation lubricant. Please refer to page Eng-12 for further details.

Dust Prevention:

Dust and dirt can affect the accuracy and life of a slide way. A slide way used in a hostile environment should be protected with a cover (Figure H-10).

Figure H-10 Use of Cover to Prevent Dust

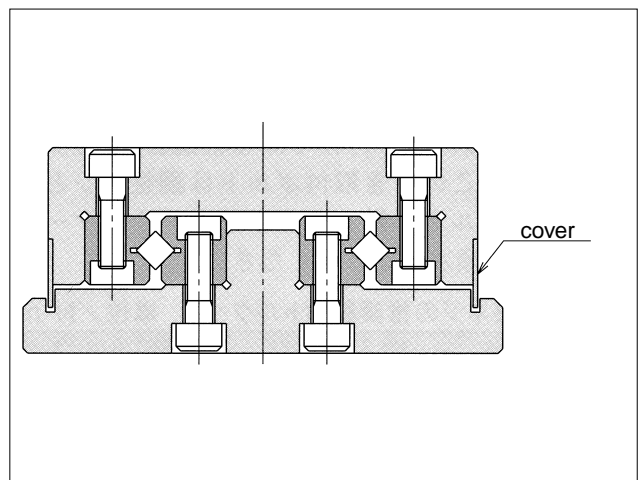

NOTES ON OPERATION

Pre-load Adjustment:

Inaccurate pre-load adjustment may reduce the motion accuracy, resulting in skewing and shortening of slide way life. The pre-load should be adjusted carefully.

Cage Slippage:

When used under high-speed, unbalanced-load, or vibrational conditions, cage slippage may occur. The stroke distance should be determined with sufficient margin, and an excessive pre-load should not be applied.

End Pieces:

End pieces are attached to each end of the slide way to prevent removal of the cage. Do not use them as a mechanism stopper.

Knock Pin Hole:

When using SVW type knock pin holes to attach a slide way, the holes on the mounting surface should be machined after attaching the W type rail. After machining, remove the chips completely and wash as required.

Careful Handling:

Dropping a slide way may result in scratches or dents on the raceway surface, preventing smooth motion and affecting accuracy. Care should be exercised in handling.

Use as a Set:

The accuracy tolerance of a slide way is designed to be adjusted within a particular set of components. If components from different sets are used, accuracy may be affected.

SV TYPE

— SV1/SV2 —

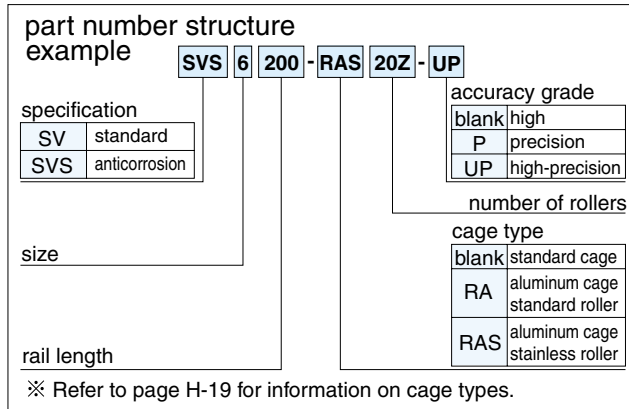
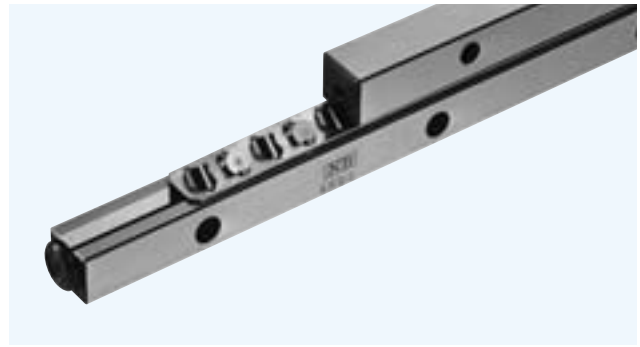

part number		stroke mm	roller diameter D mm	number of rollers Z				
standard	anticorrosion				L mm	A mm	B mm	C mm
SV1020-5Z	SVS1020-5Z	12	1.5	5	20	8.5	4	3.8
1030-7Z	1030-7Z	20		7	30			
1040-10Z	1040-10Z	27		10	40			
1050-13Z	1050-13Z	32		13	50			
1060-16Z	1060-16Z	37		16	60			
1070-19Z	1070-19Z	42		19	70			
1080-21Z	1080-21Z	50		21	80			
SV2030-5Z	SVS2030-5Z	18		2	5			
2045-8Z	2045-8Z	24	8		45			
2060-11Z	2060-11Z	30	11		60			
2075-13Z	2075-13Z	44	13		75			
2090-16Z	2090-16Z	50	16		90			
2105-18Z	2105-18Z	64	18		105			
2120-21Z	2120-21Z	70	21		120			
2135-23Z	2135-23Z	84	23		135			
2150-26Z	2150-26Z	90	26		150			
2165-29Z	2165-29Z	95	29		165			
2180-32Z	2180-32Z	100	32		180			

Maximum Rail Length (SV type only)

part number	Max.length
SV1	200mm
SV2	450mm

Please contact NB for further details.

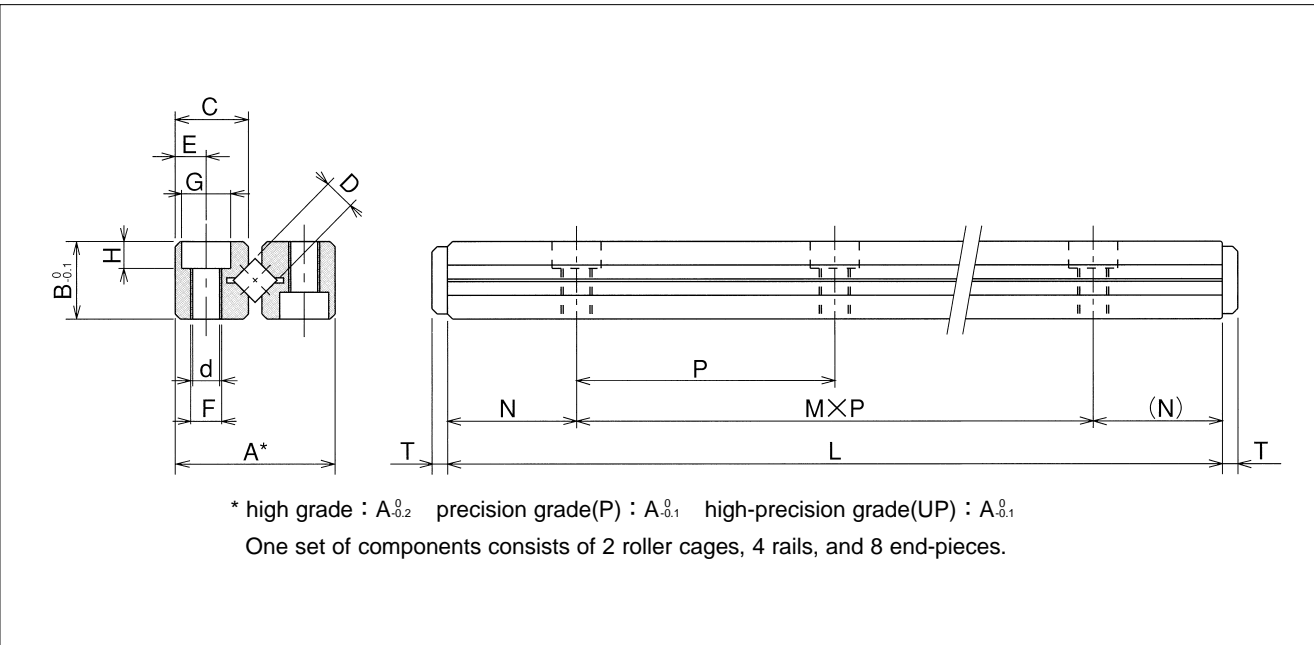

major dimensions								basic load rating		mass g	size
M×P mm	N mm	E mm	F	d mm	G mm	H mm	T mm	dynamic C N	static Co N		
1×10								340	312	11	1020
2×10								461	468	14	1030
3×10								676	780	18	1040
4×10	5	1.8	M2	1.65	3	1.4	0.8	776	936	22	1050
5×10								962	1,250	26	1060
6×10								1,050	1,400	30	1070
7×10								1,140	1,560	34	1080
1×15								594	588	28	2030
2×15								999	1,180	42	2045
3×15								1,180	1,470	55	2060
4×15								1,350	1,760	69	2075
5×15								1,680	2,350	83	2090
6×15	7.5	2.5	M3	2.55	4.4	2	2	1,840	2,650	96	2105
7×15								1,990	2,940	110	2120
8×15								2,130	3,230	123	2135
9×15								2,420	3,820	137	2150
10×15								2,560	4,120	151	2165
11×15								2,830	4,700	165	2180

1N≐0.102kgf

SV TYPE

— SV3/SV4 —

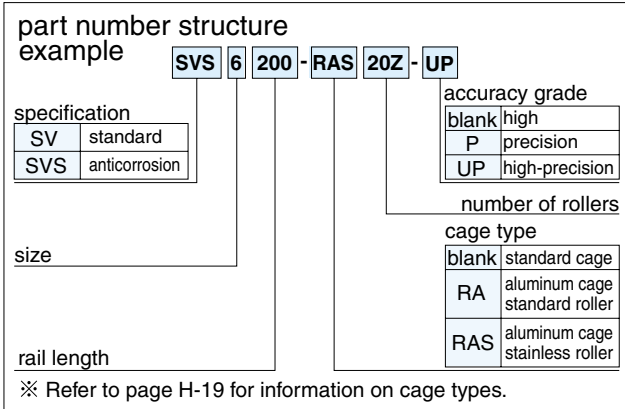
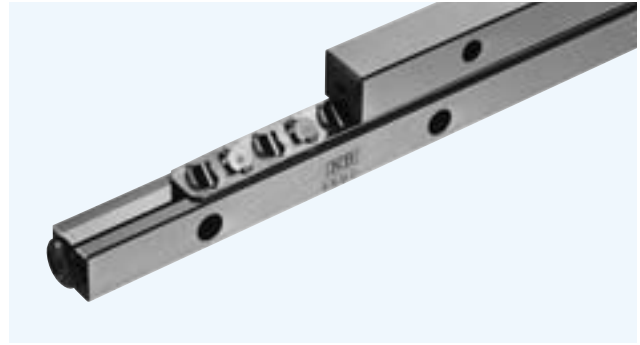

part number		stroke mm	roller diameter D mm	number of rollers Z	L	A	B	C
standard	anticorrosion				mm	mm	mm	mm
SV3050-7Z	SVS3050-7Z	28	3	7	50	18	8	8.3
3075-10Z	3075-10Z	48		10	75			
3100-14Z	3100-14Z	58		14	100			
3125-17Z	3125-17Z	78		17	125			
3150-21Z	3150-21Z	88		21	150			
3175-24Z	3175-24Z	105		24	175			
3200-28Z	3200-28Z	115		28	200			
3225-31Z	3225-31Z	135		31	225			
3250-35Z	3250-35Z	145		35	250			
3275-38Z	3275-38Z	165		38	275			
3300-42Z	3300-42Z	175		42	300			
3325-45Z	3325-45Z	195		45	325			
3350-49Z	3350-49Z	205		49	350			
SV4080-7Z	SVS4080-7Z	58	4	7	80	22	11	10.2
4120-11Z	4120-11Z	82		11	120			
4160-15Z	4160-15Z	105		15	160			
4200-19Z	4200-19Z	130		19	200			
4240-23Z	4240-23Z	150		23	240			
4280-27Z	4280-27Z	175		27	280			
4320-31Z	4320-31Z	200		31	320			
4360-35Z	4360-35Z	225		35	360			
4400-39Z	4400-39Z	250		39	400			
4440-43Z	4440-43Z	270		43	440			
4480-47Z	4480-47Z	295		47	480			

Maximum Rail Length (SV type only)

part number	Max.length
SV6	1000mm

Please contact NB for further details.

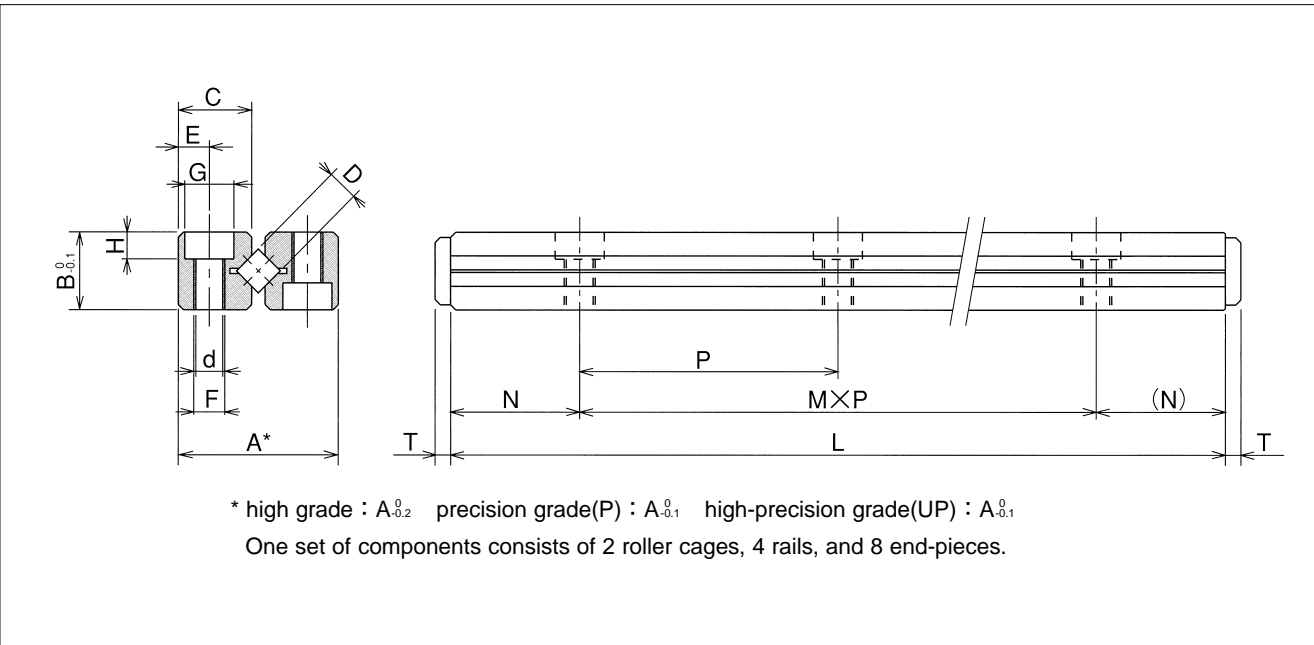

major dimensions								basic load rating		mass g	size
M×P mm	N mm	E mm	F	d mm	G mm	H mm	T mm	dynamic C N	static Co N		
1×25								1,800	2,120	94	3050
2×25								2,640	3,530	135	3075
3×25								3,400	4,940	187	3100
4×25								3,760	5,650	234	3125
5×25								4,440	7,060	281	3150
6×25								5,100	8,470	327	3175
7×25	12.5	3.5	M4	3.3	6	3.1	2	5,720	9,880	374	3200
8×25								6,020	10,600	421	3225
9×25								6,620	12,000	468	3250
10×25								7,190	13,400	514	3275
11×25								7,750	14,800	561	3300
12×25								8,030	15,500	608	3325
13×25								8,570	16,900	655	3350
1×40								3,560	4,350	255	4080
2×40								5,220	7,250	385	4120
3×40								6,720	10,200	510	4160
4×40								8,120	13,100	635	4200
5×40								9,430	16,000	770	4240
6×40	20	4.5	M5	4.3	8	4.2	2	10,700	18,900	905	4280
7×40								11,900	21,800	1,020	4320
8×40								13,100	24,700	1,160	4360
9×40								14,200	27,600	1,280	4400
10×40								15,300	30,500	1,410	4440
11×40								16,400	33,400	1,540	4480

1N≐0.102kgf

SV TYPE

— SV6/SV9 —

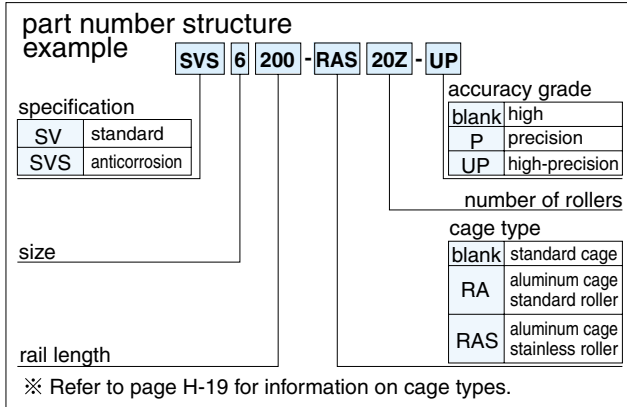
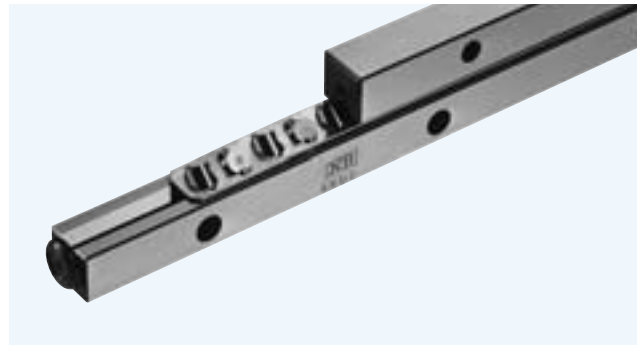

part number		stroke mm	roller diameter D mm	number of rollers Z	L	A	B	C
standard	anticorrosion				mm	mm	mm	mm
SV6100-8Z	SVS6100-8Z	55	6	8	100	31	15	14.2
6150-12Z	6150-12Z	85		12	150			
6200-16Z	6200-16Z	120		16	200			
6250-20Z	6250-20Z	150		20	250			
6300-24Z	6300-24Z	185		24	300			
6350-28Z	6350-28Z	215		28	350			
6400-32Z	6400-32Z	245		32	400			
6450-36Z	6450-36Z	280		36	450			
6500-40Z	6500-40Z	310		40	500			
6600-49Z	6600-49Z	360		49	600			
SV9200-10Z	—	115		9	10			
9300-15Z	—	175	15		300			
9400-20Z	—	235	20		400			
9500-25Z	—	295	25		500			
9600-30Z	—	355	30		600			
9700-35Z	—	415	35		700			
9800-40Z	—	475	40		800			
9900-45Z	—	535	45		900			
91000-50Z	—	595	50		1,000			

Maximum Rail Length (SV type only)

part number	Max.length
SV3	700mm
SV4	700mm

Please contact NB for further details.

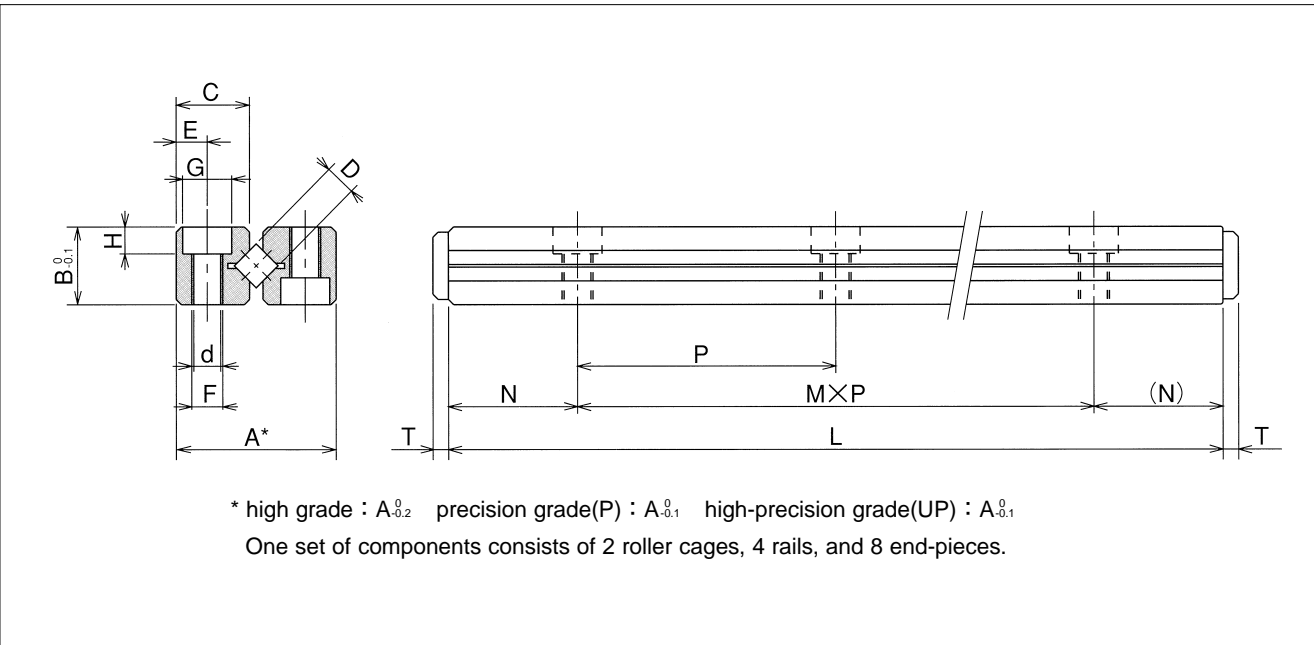

major dimensions								basic load rating		mass g	size
M×P mm	N mm	E mm	F	d mm	G mm	H mm	T mm	dynamic C N	static Co N		
1×50	25	6	M6	5.2	9.5	5.2	3	10,900	14,500	628	6100
2×50								14,700	21,700	942	6150
3×50								18,300	29,000	1,260	6200
4×50								21,600	36,200	1,570	6250
5×50								24,800	43,400	1,880	6300
6×50								27,800	50,700	2,200	6350
7×50								30,700	57,900	2,510	6400
8×50								33,600	65,200	2,830	6450
9×50								36,300	72,400	3,140	6500
11×50								41,600	86,900	3,770	6600
1×100								50	9	M8	6.8
2×100	32,500	50,800	4,030	9300							
3×100	42,500	72,600	5,380	9400							
4×100	48,700	87,100	6,700	9500							
5×100	57,600	109,000	8,050	9600							
6×100	63,300	123,000	9,230	9700							
7×100	71,500	145,000	10,500	9800							
8×100	76,800	160,000	11,900	9900							
9×100	84,500	182,000	13,000	91000							

1N≐0.102kgf

SV TYPE

– SV12 –

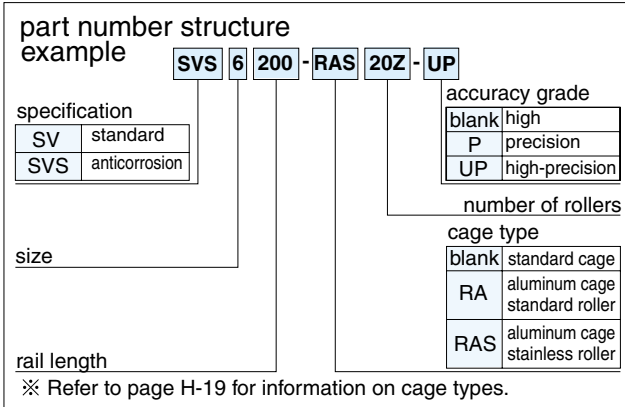
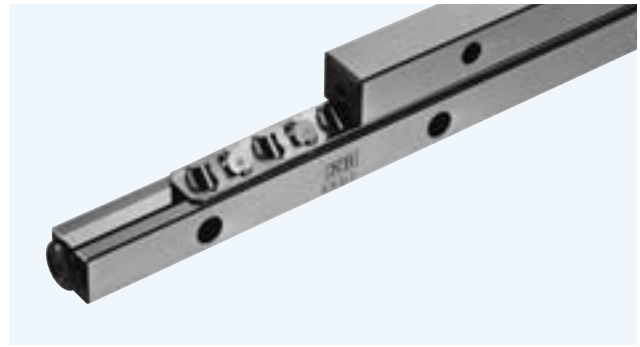

part number		stroke mm	roller diameter D mm	number of rollers Z				
standard	anticorrosion				L mm	A mm	B mm	C mm
SV12300-10Z	—	200	12	10	300	58	28	27
12400-14Z	—	240		14	400			
12500-17Z	—	320		17	500			
12600-21Z	—	360		21	600			
12700-24Z	—	440		24	700			
12800-28Z	—	480		28	800			
12900-31Z	—	560		31	900			
121000-34Z	—	640		34	1,000			
121100-38Z	—	680		38	1,100			
121200-42Z	—	720		42	1,200			

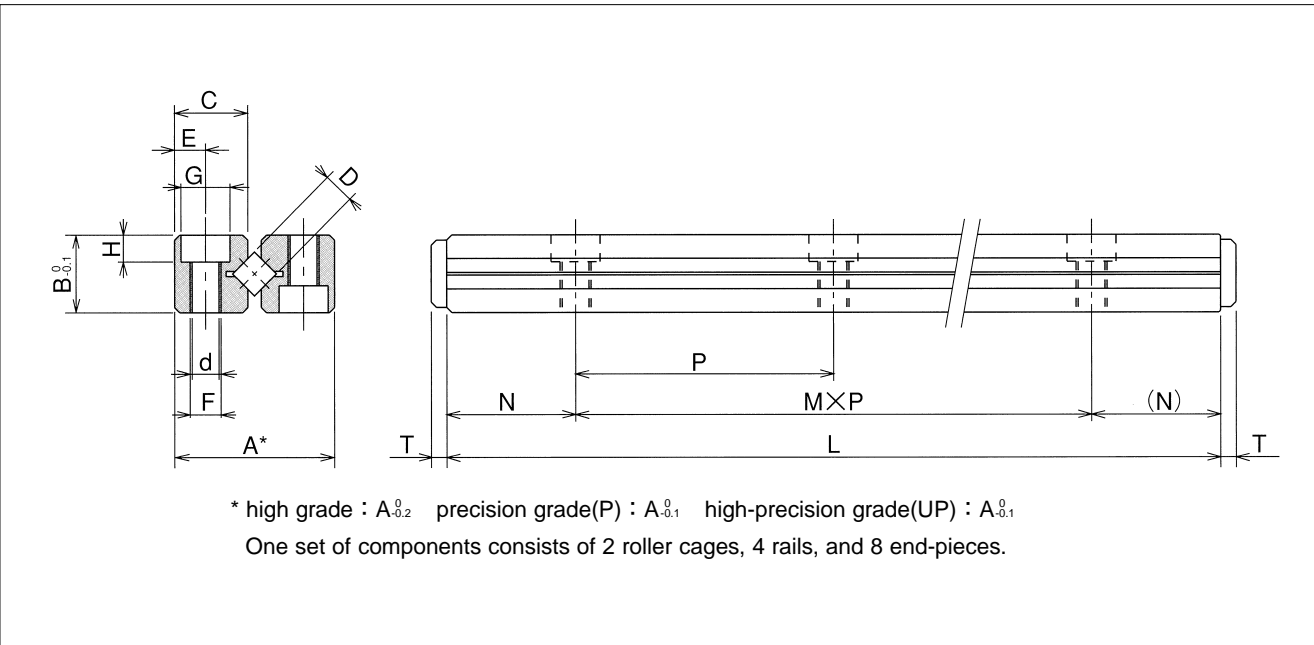

major dimensions								basic load rating		mass g	size
M×P mm	N mm	E mm	F	d mm	G mm	H mm	T mm	dynamic C N	static Co N		
2×100								42,700	73,500	6,880	12300
3×100								55,000	103,000	9,090	12400
4×100								60,800	118,000	11,400	12500
5×100								71,800	147,000	13,700	12600
6×100	50	12	M10	8.5	13.5	8.2	4	82,400	176,000	15,800	12700
7×100								92,400	206,000	18,200	12800
8×100								97,400	221,000	20,500	12900
9×100								107,000	250,000	22,800	121000
10×100								116,000	279,000	25,000	121100
11×100								125,000	309,000	27,300	121200

1N≒0.102kgf

SVW TYPE

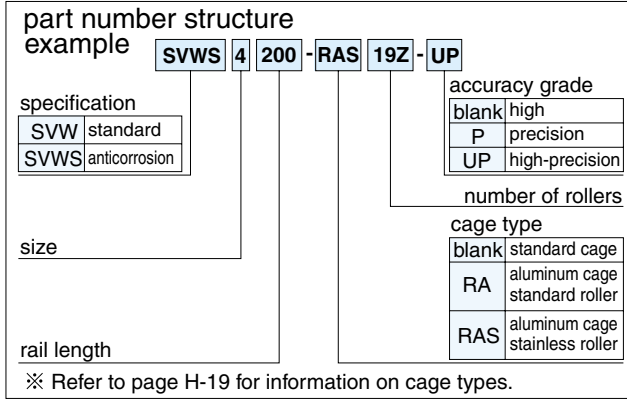
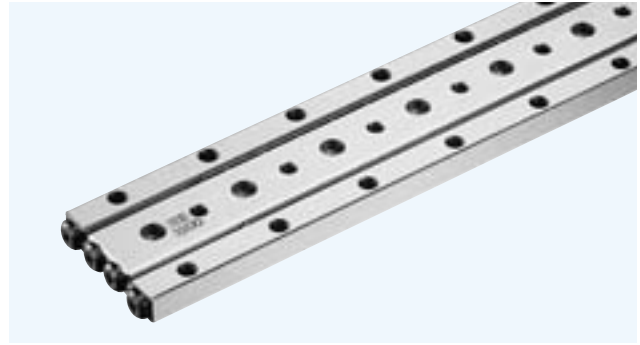

part number		stroke mm	roller diameter D mm	number of rollers Z	L mm	A mm	t mm	B ₁ mm	B ₂ mm	C mm	P ₁ mm	M ₁ ×P ₂ mm
standard	anticorrosion											
SVW1020- 5Z	SVWS1020- 5Z	12		5	20							1×10
1030- 7Z	1030- 7Z	20		7	30							2×10
1040-10Z	1040-10Z	27		10	40							3×10
1050-13Z	1050-13Z	32	1.5	13	50	4.5	0.5	17	7.6	3.8	13.4	4×10
1060-16Z	1060-16Z	37		16	60							5×10
1070-19Z	1070-19Z	42		19	70							6×10
1080-21Z	1080-21Z	50		21	80							7×10
SVW2030- 5Z	SVWS2030- 5Z	18		5	30							1×15
2045- 8Z	2045- 8Z	24		8	45							2×15
2060-11Z	2060-11Z	30		11	60							3×15
2075-13Z	2075-13Z	44	2	13	75	6.5	0.5	24	11	5.5	19	4×15
2090-16Z	2090-16Z	50		16	90							5×15
2105-18Z	2105-18Z	64		18	105							6×15
2120-21Z	2120-21Z	70		21	120							7×15
SVW3050- 7Z	SVWS3050- 7Z	28		7	50							1×25
3075-10Z	3075-10Z	48		10	75							2×25
3100-14Z	3100-14Z	58		14	100							3×25
3125-17Z	3125-17Z	78	3	17	125	8.5	0.5	36	16.6	8.3	29	4×25
3150-21Z	3150-21Z	88		21	150							5×25
3175-24Z	3175-24Z	105		24	175							6×25
3200-28Z	3200-28Z	115		28	200							7×25
SVW4080- 7Z	SVWS4080- 7Z	58		7	80							1×40
4120-11Z	4120-11Z	82		11	120							2×40
4160-15Z	4160-15Z	105	4	15	160	11.5	0.5	44	20.4	10.2	35	3×40
4200-19Z	4200-19Z	130		19	200							4×40
4240-23Z	4240-23Z	150		23	240							5×40
4280-27Z	4280-27Z	175		27	280							6×40

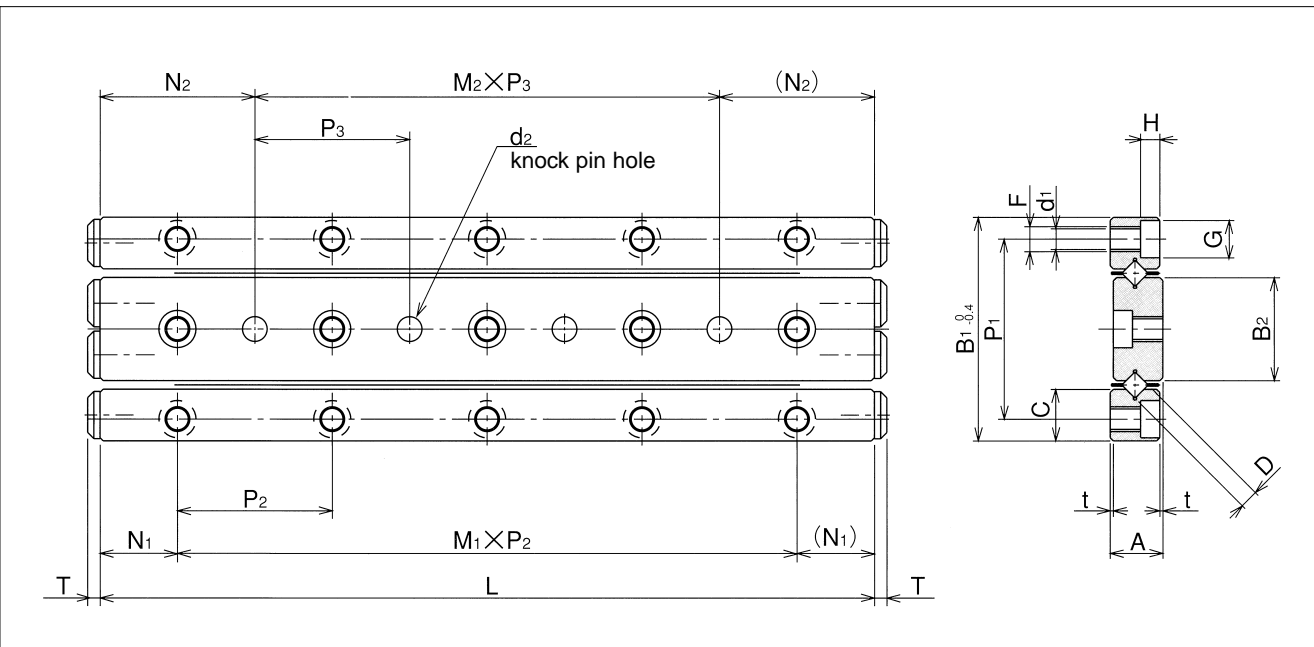

major dimensions									basic load rating		mass g	size
N ₁ mm	F	d ₁ mm	G mm	H mm	M ₂ ×P ₃ mm	N ₂ mm	d ₂ mm	T mm	dynamic C N	static C ₀ N		
5	M2	1.65	3	1.4	—	10	2	1	340	312	11	1020
					1×10				461	468	14	1030
					2×10				676	780	18	1040
					3×10				776	936	22	1050
					4×10				962	1,250	26	1060
					5×10				1,050	1,400	30	1070
6×10	1,140	1,560	34	1080								
7.5	M3	2.55	4.4	2	—	15	3	2	594	588	28	2030
					1×15				999	1,180	42	2045
					2×15				1,180	1,470	55	2060
					3×15				1,350	1,760	69	2075
					4×15				1,680	2,350	83	2090
					5×15				1,840	2,650	96	2105
6×15	1,990	2,940	110	2120								
12.5	M4	3.3	6	3.1	—	25	4	2	1,800	2,120	94	3050
					1×25				2,640	3,530	135	3075
					2×25				3,400	4,940	187	3100
					3×25				3,760	5,650	234	3125
					4×25				4,440	7,060	281	3150
					5×25				5,100	8,470	327	3175
6×25	5,720	9,880	374	3200								
20	M5	4.3	8	4.2	—	40	5	2	3,560	4,350	255	4080
					1×40				5,220	7,250	385	4120
					2×40				6,720	10,200	510	4160
					3×40				8,120	13,100	635	4200
					4×40				9,430	16,000	770	4240
5×40	10,700	18,900	905	4280								

1N≒0.102kgf

STROKE AND RATED LOAD

When the stroke is changed, the new stroke distance must be determined and the rated load must be re-estimated as follows.

Stroke:

When the slide way moves along the tracking base, the cage moves half the distance traveled by the slide way in the same direction. Therefore, although the applied load may be fixed on the table, the distance between the load center and cage center will change. To achieve stable accuracy, determine the stroke distance and length of the tracking base as follows:

Figure H-11 Travel Distance

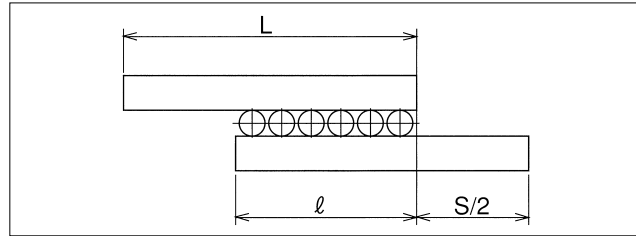

Rail length (L)

When the stroke is 400mm or over

$$S \leq L / 1.5$$

When the stroke is less than 400 mm,

$$S \leq L$$

Cage length (l)

$$l \leq L - \frac{S}{2}$$

Number of rollers (Z)

$$Z = \frac{l - 2a}{p} + 1$$

S : stroke (mm) L : rail length (mm)

a,P : Refer to roller cage dimensions (Page H-19)

Rated Load:

The rated load for the slide way is obtained using the equations listed in Table H-4.

Table H-4 Rated Load

condition	single-rail usage	single-rail vertical usage	double-rail parallel usage
direction of load			
basic dynamic load rating C	$C = \left(\frac{Z}{2}\right)^{3/4} \cdot C_1$	$C = \left(\frac{Z}{2}\right)^{3/4} \cdot C_1 \cdot 2^{7/9}$	
basic static load rating Co	$Co = \frac{Z}{2} \cdot Co_1$	$Co = \frac{Z}{2} \cdot Co_1 \cdot 2$	

C : basic dynamic load rating (N) Co : basic static load rating (N) C₁ : basic dynamic load rating per roller (N) Co₁ : basic static load rating per roller (N)
Z : number of rollers per cage Z / 2 : effective roller number (round down to whole number)

R/RS TYPE

— Roller Cage —

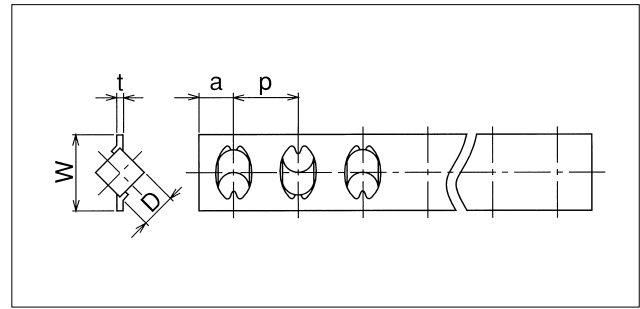

part number structure example

RS 6 - 15Z

number of rollers

specification

R	standard
RS	anticorrosion

size

part number		D mm	t mm	W mm	p mm	a mm	C ₁ N	Co ₁ N
standard	anticorrosion							
R 1	RS1	1.5	0.2	3.8	2.5	2	118	78
R 2	RS2	2	0.3	5.6	4	2.5	206	147
R 3	RS3	3	0.4	7.6	5	3	461	353
R 4	RS4	4	0.4	10.4	7	4.5	911	725
R 6	RS6	6	0.7	14	8.5	5.5	2,240	1,810
R 9	—	9	0.7	19	14	7.5	4,410	3,630
R12	—	12	1.0	25	20	10	7,450	7,350

cage material : stainless steel C₁ : dynamic load rating per roller Co₁ : static load rating per roller

RA/RAS TYPE

— Aluminum Roller Cage —

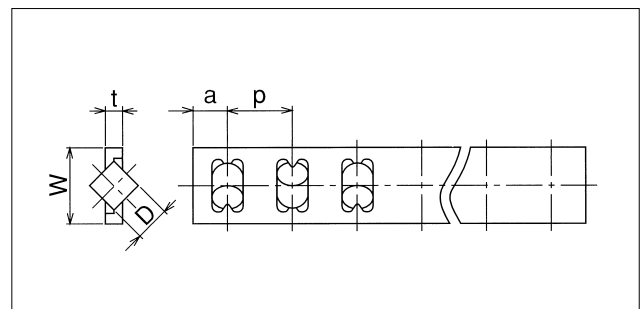

part number structure example

RAS 6 - 15Z

number of rollers

specification

RA	standard
RAS	anticorrosion

size

part number		D mm	t mm	W mm	p mm	a mm	C ₁ N	Co ₁ N
standard	anticorrosion							
RA3	RAS3	3	1.2	7.6	5	3	461	353
RA4	RAS4	4	1.4	10.4	7	4.5	911	725
RA6	RAS6	6	2.1	14	8.5	5.5	2,240	1,810
RA9	—	9	3.0	20	14	7.5	4,410	3,630

cage material : aluminum C₁ : dynamic load rating per roller Co₁ : static load rating per roller