

# SLIDE GUIDE SGL TYPE

The SGL slide guide is a linear motion bearing utilizing the rotational motion of ball elements along four rows of raceway grooves. It can be used in various applications due to its compactness and high load capacity.

## STRUCTURE AND ADVANTAGES

SGL slide guides consist of a rail with four precision-machined raceway grooves and a block assembly. The block assembly consists of the main body, ball elements, retainers, and return caps.

### High Load Capacity and Long Life:

The use of larger ball elements and a raceway with grooves machined to a radius close to that of the ball elements increases the area of the contact surface. The results are load capacity and provides longer life.

### Low Wear:

Because a 4-row/2-point contact design is used, low wear and stable motion characteristics are achieved even under a pre-loaded conditions.

### Omni-Directional Load Capacity:

The ball elements are positioned at 45° contact angle so that the load capacity is equal in four directions (above, underneath, right and left).

### Absorption of Mounting Dimensional Error:

Because the ball elements are positioned to increase their self-aligning characteristics, the dimensional error caused during installation is absorbed.

### Anti-Corrosion Specification:

The rail and block assembly may be Raydent treated to increase the corrosion resistance. This treatment is standardized with the symbol "RD", and suitable for use in clean room applications.

### Dust Prevention:

Side seals are provided as a standard. To improve the dust prevention characteristics, underseals and special rail mounting caps are also available.

Figure A-45 Structure of SGL type Slide Guide

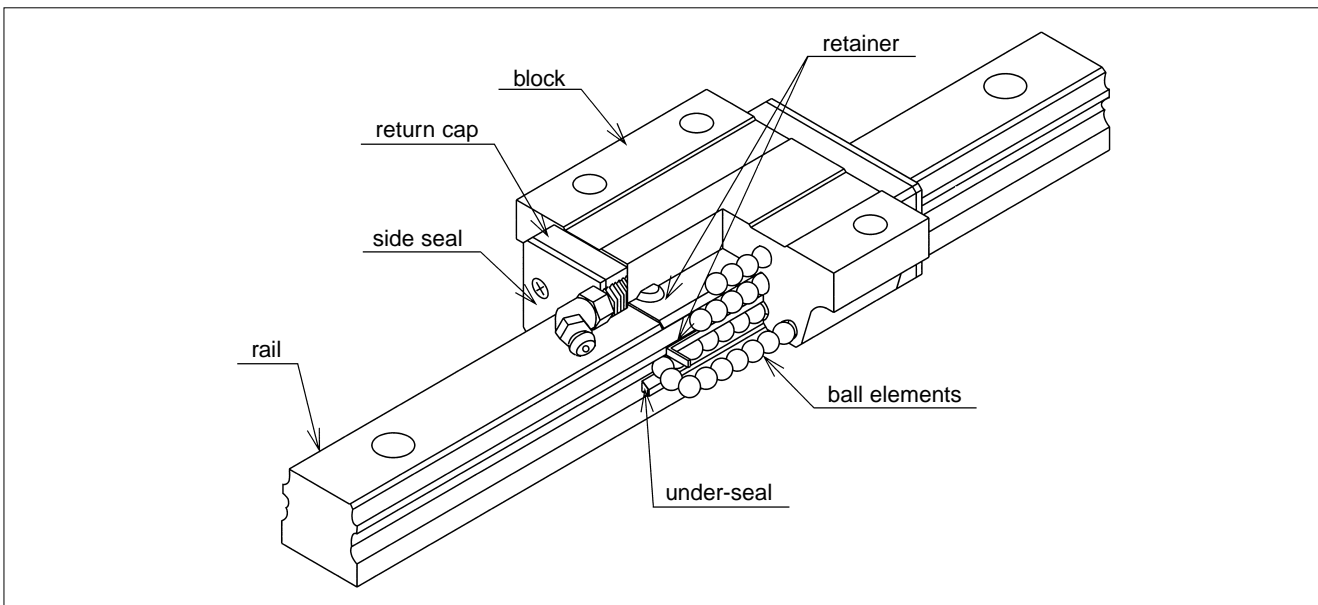

## BLOCK TYPES

Six different types of blocks are available depending on the mounting space requirements and desired mounting method.

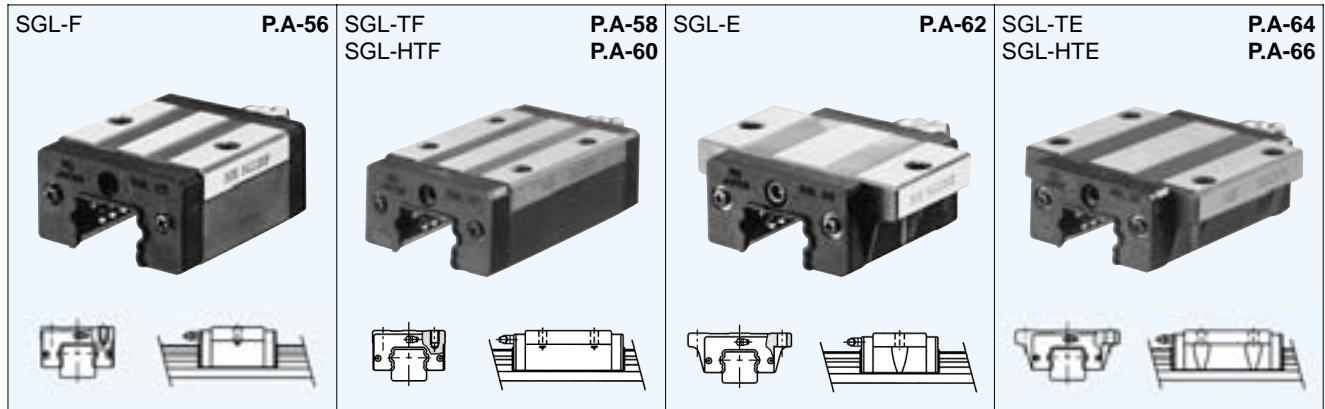

## ACCURACY

Three accuracy grades are available: normal-grade (no suffix), high-grade (H), and precision-grade (P).

Table A-23 Accuracy

unit/mm

part number	SGL15,20			SGL25,30,35		
	normal	high	precision	normal	high	precision
accuracy grade	normal	high	precision	normal	high	precision
accuracy symbol	none	H	P	none	H	P
allowable dimensional tolerance for height H	±0.1	±0.03	-0.03~0	±0.1	±0.04	-0.04~0
paired difference for height H	0.02	0.01	0.006	0.02	0.015	0.007
allowable dimensional tolerance for width W	±0.1	±0.03	-0.03~0	±0.1	±0.04	-0.04~0
paired difference for width W	0.02	0.01	0.006	0.03	0.015	0.007
Running parallelism of surface C to surface A Running parallelism of surface D to surface B	refer to Figure A-46					

Figure A-46 Motion Accuracy

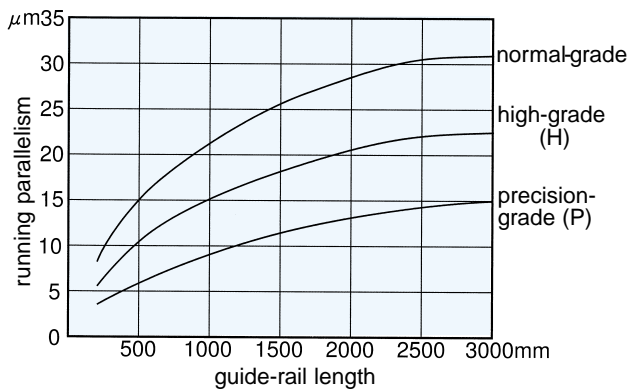
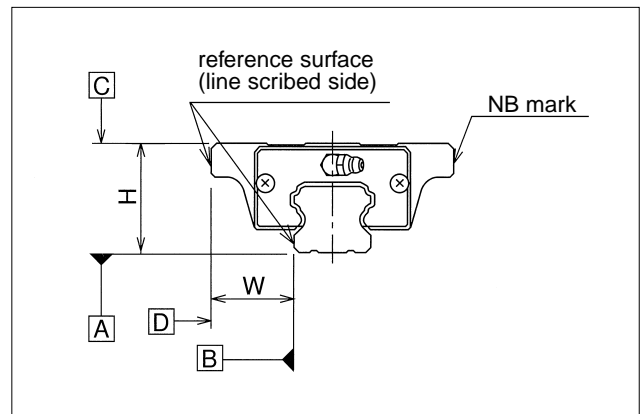

Figure A-47 Accuracy



## PRE-LOAD

SGL slide guides are available with a standard pre-load(no suffix), light pre-load(T<sub>1</sub>), and medium pre-load(T<sub>2</sub>).

Table A-24 Pre-Load Symbol and Radial Clearance unit/ $\mu\text{m}$

pre-load category	standard	light	medium
pre-load symbol	none	T1	T2
SGL15	-4~+2	-12~-4	-
SGL20	-5~+2	-14~-5	-23~-14
SGL25	-6~+3	-16~-6	-26~-16
SGL30	-7~+4	-19~-7	-31~-19
SGL35	-8~+4	-22~-8	-35~-22

Table A-25 Operating Condition and Pre-Load

category	symbol	operating condition
standard	none	Minute vibration is applied. Precision motion is required. Moment in a given direction is applied.
light	T1	Light vibration is applied. Light moment is applied. Moment is applied.
medium	T2	Shock/vibration is applied. Over-hang load is applied. Torsional load is applied.

## RAIL LENGTH

Slide guides with most commonly used lengths are available as standard. Unless otherwise specified, the distance to the first mounting hole (N) from one end of the rail will be located within the range listed in Table A-26 for slide guides that have a non-standard length satisfying the following equation.

$$L = M \cdot P + 2N$$

L : length (mm) N : distance to the first hole from the end of the rail (mm)  
M : number of pitches P : hole pitch (mm)

Table A-26 Fabrication Range

unit/mm

part number	N		Lmax
	and over	less than	
SGL15	6	36	2,000
SGL20	10	40	
SGL25	11	41	
SGL30	12	52	
SGL35	16	56	

Figure A-48 Rail

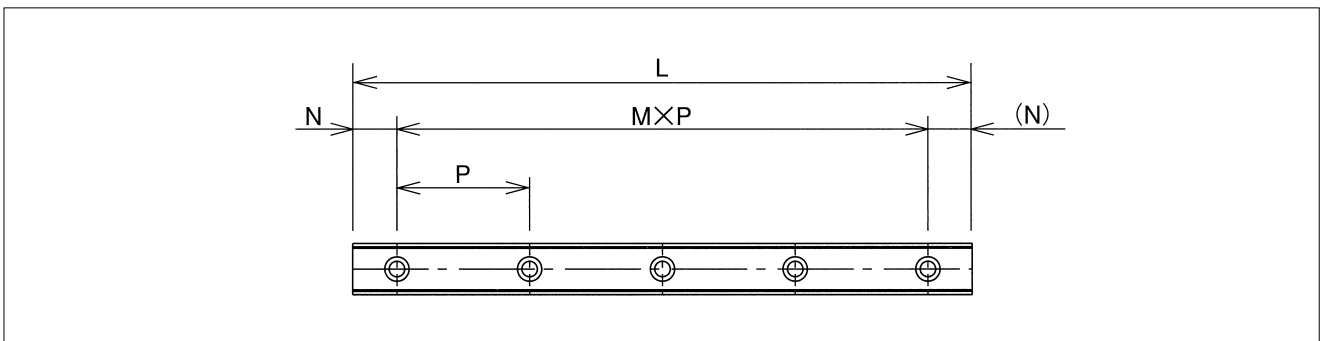

## MOUNTING

Slide guides are generally mounted by pushing the reference surface of the rail and block against the shoulder of the mounting surface. An escape groove should be provided at the corner of the shoulder in order to avoid interference with the corner of the rail or block.

The bolts used to secure the rail should be tightened using a torque wrench. The recommended torque values are listed in Table A-27.

Table A-27 Recommended Torque

part number		bolt size	recommended torque (N-m)
SGL-F,E,TF,TE	SGL-HTF,HTE		
15	—	M3	2.0
15-D	15	M4	3.9
20	20	M5	8.8
25	25	M6	12.7
30,35	30,35	M8	29.4

Figure A-49 Mounting Reference Surface Shapes

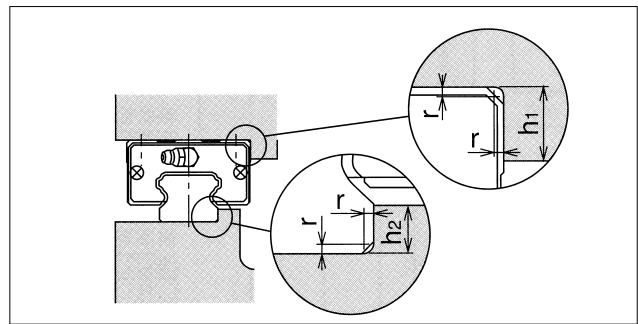

Table A-28 Mounting Surface Dimensions

unit/mm

part number	$h_1$	$h_2$	$r_{max}$
SGL15	4	3.5	0.5
SGL20	5	5	0.5
SGL25	5	5.5	1
SGL30	6	7.5	1
SGL35	6	8	1

## GREASE FITTING

A grease fitting is attached to the SGL slide guide in the return cap for lubrication purposes. Unless otherwise specified, the orientation of the grease fitting is as shown in Figure A-50. When more than 2 blocks are used on one rail, the grease fitting orientation must be specified.

Figure A-50 Number of Blocks and Grease Fitting Orientation

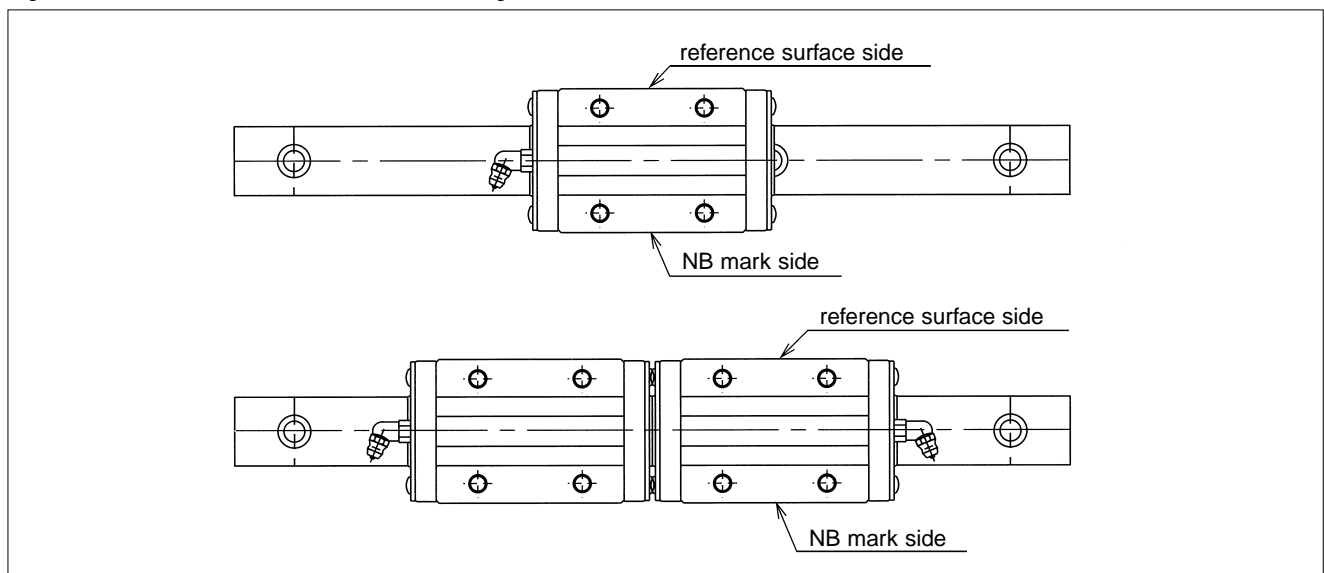

## BELLOWS

By protecting the entire length of Guide Rails, the dust prevention is greatly enhanced. Please refer to Figure A-51 for dimensional information.

External dimensions and the stroke of Slide Guide are affected when using bellows.

Figure A-51 Dimensions of Slide Guide with Bellows

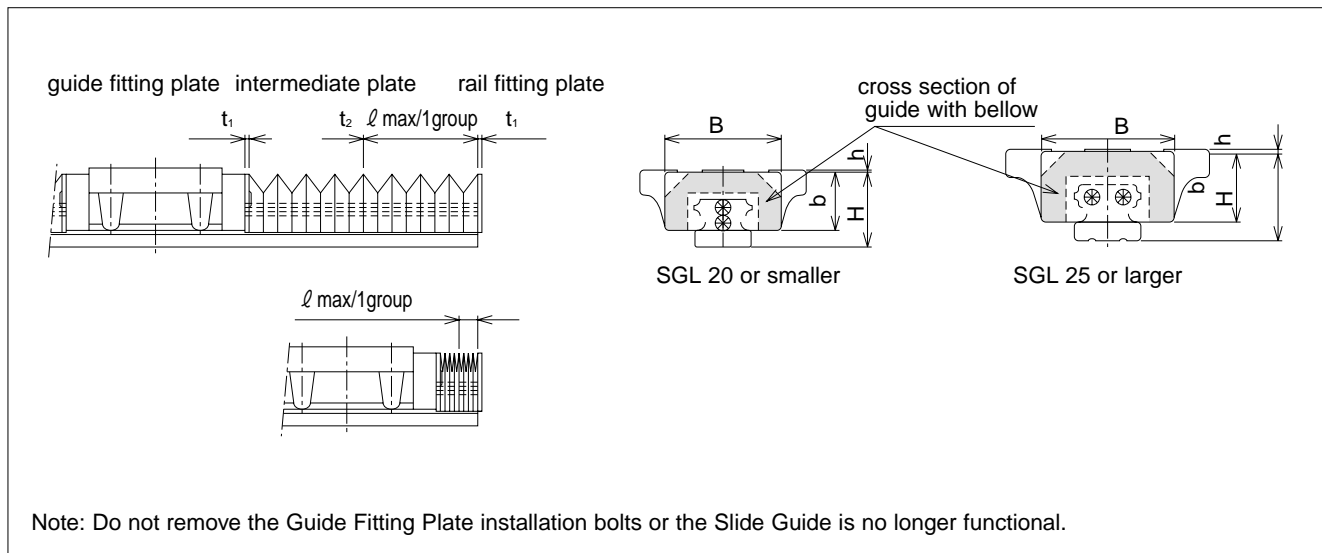

Part Number	B	H	h	b	t1	t2	ℓ max/1 group	ℓ min/1 group
SGL 15F/TF/E/TE	33	23	1	19	1.6	0.5	32	6.5
SGL 15HTE			5					
SGL 15HTF			5					
SGL 20F/TF/E/TE	41	27	1	21.5				
SGL 20HTF/HTE			3					
SGL 25F/TF/E/TE			1					
SGL 25HTF	47	32	8	25.5				
SGL 25HTE			4					
SGL 30F/TF/E/TE	58	40	2	31				
SGL 30HTE			5					
SGL 30HTF			5					
SGL 35F/TF/E/TE	68	46	2	37				
SGL 35HTE			9					
SGL 35HTF			9					

Note: 1 group indicates the minimum unit of bellows.

When bellows are fitted to the Guide Block, the grease fitting cannot be installed.

Please contact NB for details on the installation of bellows, as well as for special application usage.

## Calculation method of length of Bellows and Slide Guide Rails

Example) In this case, one(1) piece of SGL15TE Guide Block is mounted on a Rail with Bellows; the required stroke is 420mm. Group numbers required for a stroke of 420mm is calculated as illustrated below.

$$\frac{\text{Stroke}}{\ell_{\max} - \ell_{\min}} = \frac{420}{32-6.5} = 16.4 \approx 17 \text{ groups}$$

When 17 groups of Bellows are fitted, the maximum length  $\ell_1$  is calculated:

$$\ell_1 = \text{guide fitting plate} + \ell_{\max}/1 \text{ group} \times \text{number of groups} = 1.6 + 32 \times 17 = 545.6$$

When 17 groups of Bellows are fitted, the maximum length  $\ell_2$  is calculated:

$$\begin{aligned} \ell_2 &= \text{guide fitting plate} + \ell_{\min}/1 \text{ group} \times \text{number of groups} + \text{intermediate plate} \times (\text{number of groups}-1) \\ &= 1.6 + 6.5 \times 17 + 0.5 \times (17-1) = 120.1 \end{aligned}$$

With these calculation results, stroke limit(S) and length of the guide rail needed(L) are obtained as follows:

$$S = \ell_1 - \ell_2 = 545.6 - 120.1 = 425.5$$

$$L = \ell_1 + \ell_2 + \text{length of SGL 15TE block} = 545.6 + 120.1 + 56.5 = 722.2 = 723$$

Figure A-52 External diagram of Slide Guide with bellows attached

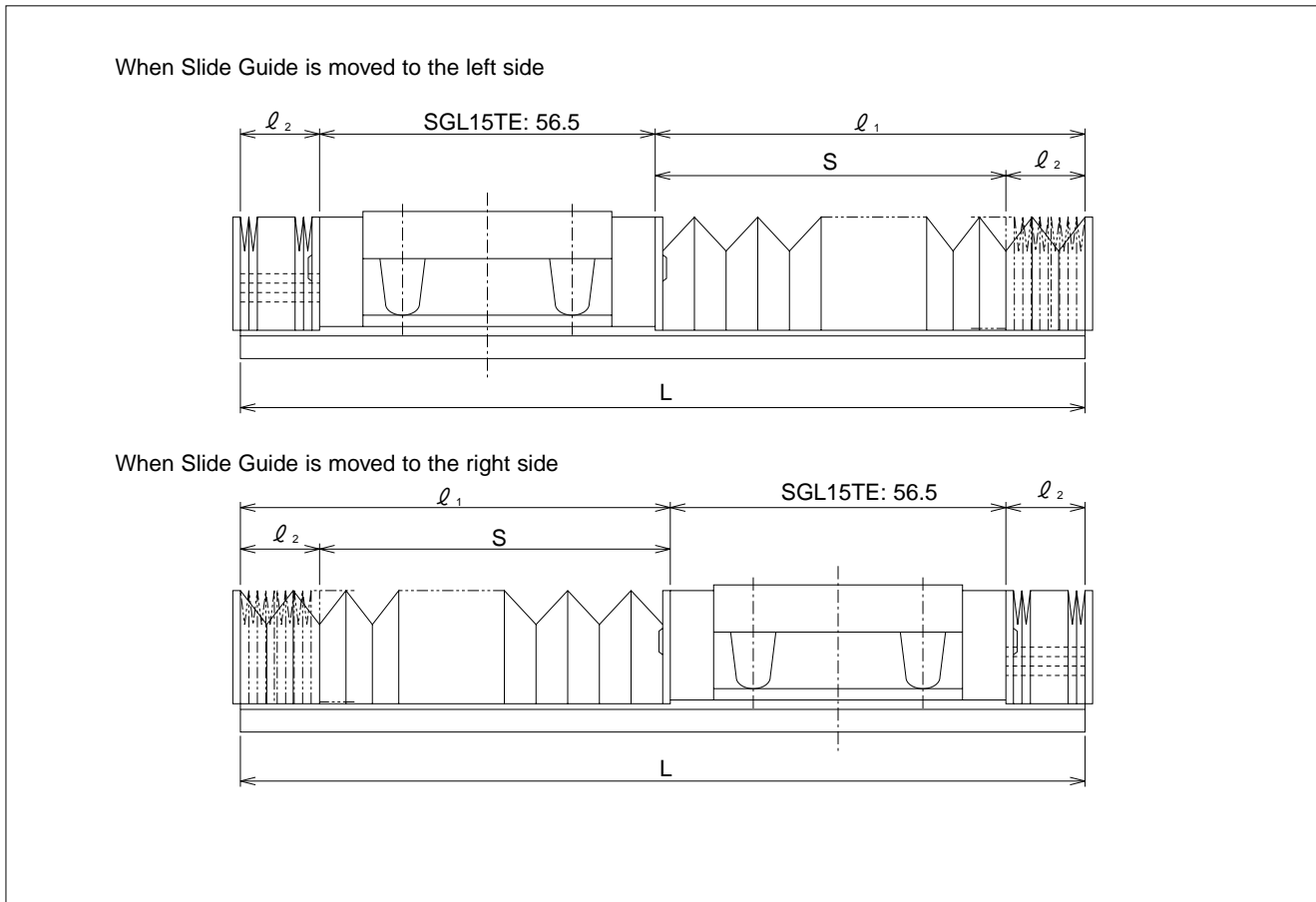

# SGL-F TYPE

— High Rigidity Non-Flange Type — (Short Configuration)

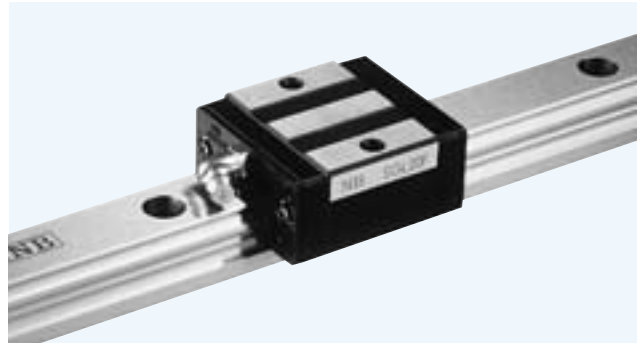

**part number structure**

example: **SGL 15 F B 2 T1 - 589 D P / W2 RD F J**

SGL type	size	block style	seal	number of blocks per rail	symbol for pre-load	size of rail installation hole	total length of rail	with bellows with rail mounting hole caps	with Raydent treatment	symbol for number of rails	accuracy grade
			blank with side-seals B seals on both ends + under-seals BW Double-seals on both ends + under-seals BS B + scraper		blank standard T1 light T2 medium					blank single rail W2 double rails W3 triple rails	blank standard H high P precision

Note: The symbol for the number of rail does not mean the number of rails ordered.

part number	assembly dimensions		block dimensions													grease fitting
	H	W	B	L <sub>1</sub>	L <sub>2</sub>	L <sub>3</sub>	L <sub>4</sub>	P <sub>1</sub>	S <sub>1</sub>	∅	T	b	E <sub>1</sub>	E <sub>2</sub>	T <sub>1</sub>	
<b>SGL15F</b> <b>SGL15F-D</b>	24	9.5	34	40.7	22.7	46.9	47.3	26	M4	7	6	19.5	6	5.4	5	pressed fitting
<b>SGL20F</b>	28	11	42	47.9	29.5	54.1	54.5	32	M5	8	7.5	22	14	13.3	6	B-M6F
<b>SGL25F</b>	33	12.5	48	58.9	37.7	65.1	65.9	35	M6	9	8	26		13.1	6.5	
<b>SGL30F</b>	42	16	60	68	40	76.6	75.6	40	M8	12	9	32.5		14.0	9	
<b>SGL35F</b>	48	18	70	77	46	85.6	84.6	50			13	38	8.5			

part number	standard rail length														
	L mm														
<b>SGL15</b>	160	220	280	340	400	460	520	580	640	700	760	820	880	940	1,000
<b>SGL20</b>	220	280	340	400	460	520	580	640	700	760	820	880	940	1,000	1,120
<b>SGL25</b>	220	280	340	400	460	520	580	640	700	760	820	880	940	1,000	1,120
<b>SGL30</b>	280	360	440	520	600	680	760	840	920	1,000	1,080	1,160	1,240	1,320	1,400
<b>SGL35</b>	280	360	440	520	600	680	760	840	920	1,000	1,080	1,160	1,240	1,320	1,400

Rails exceeding the maximum specified length may be fabricated if joints are used. Contact NB for assistance.

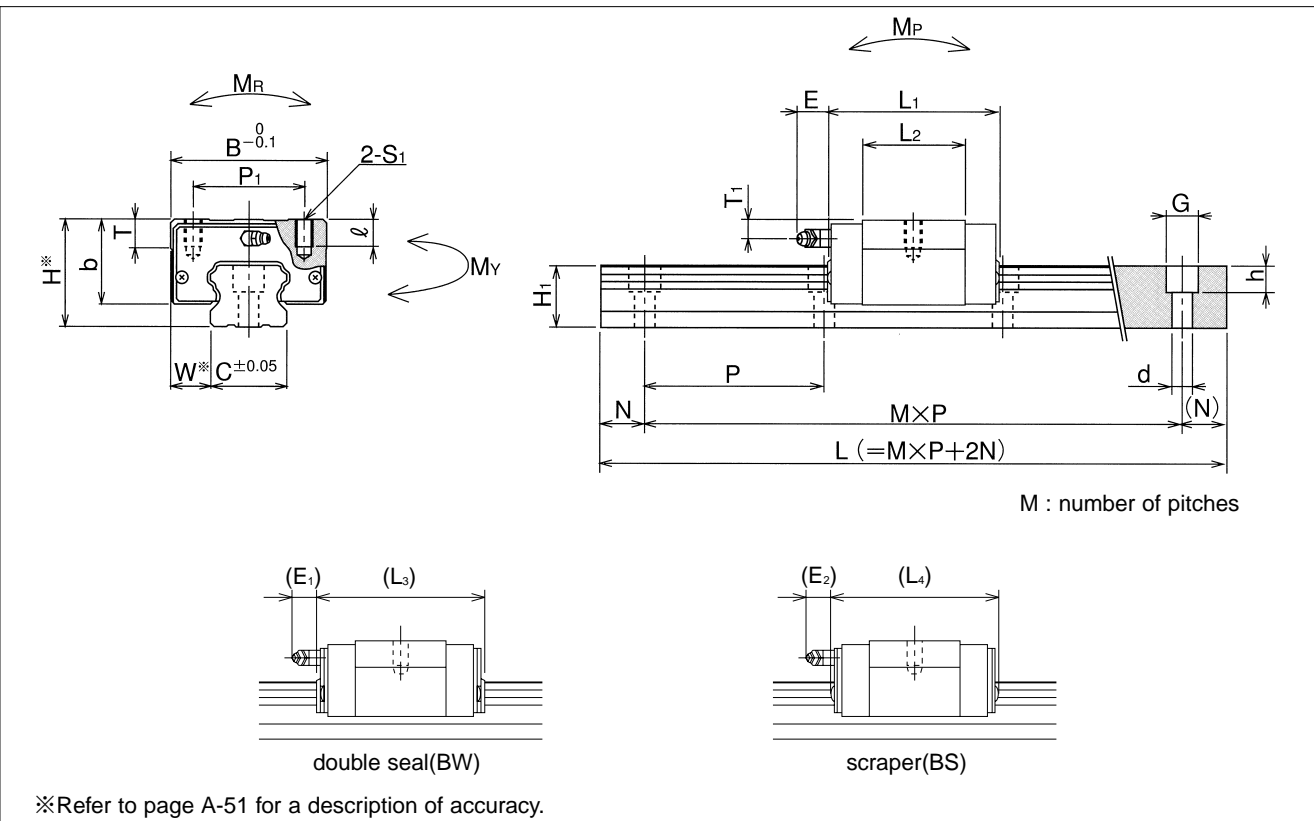

guide-rail dimensions					basic load rating		allowable static moment			mass		size	
H <sub>1</sub>	C	d × G × h	N	P	dynamic C	static C <sub>0</sub>	M <sub>P</sub> M <sub>P2</sub>	M <sub>V</sub> M <sub>V2</sub>	M <sub>R</sub>	block kg	guide rail kg/m		
mm	mm	mm	mm	mm	kN	kN	N · m	N · m	N · m	kg	kg/m		
13.5	15	3.5 × 6 × 4.5	20	60	5.00	8.23	33	33	57	0.1	1.3	<b>15</b>	
		4.5 × 7.5 × 5.3			196	196							
16	20	6 × 9.5 × 8.5			7.35	12.3	59	59	137	0.2	2.1		<b>20</b>
20	23	7 × 11 × 9			11.7	19.6	109	109	225	0.3	3.0		<b>25</b>
					24	28	13.7	22.5	652	652	0.5		4.6
27.5	34						9 × 14 × 12	21.6	35.7	123			
			248	248	627	0.8		6.2	<b>35</b>				
					1,490	1,490	627	0.8	6.2	<b>35</b>			

1kN ≒ 102kgf    1N·m ≒ 0.102kgf·m

					maximum length mm
1,120	1,240	1,360	1,480		2,000
1,240	1,360	1,480	1,600	1,720 1,840 1,960	3,000
1,240	1,360	1,480	1,600	1,720 1,840 1,960	3,000
1,480	1,640	1,720	1,800	1,960	3,000
1,480	1,640	1,720	1,800	1,960	3,000

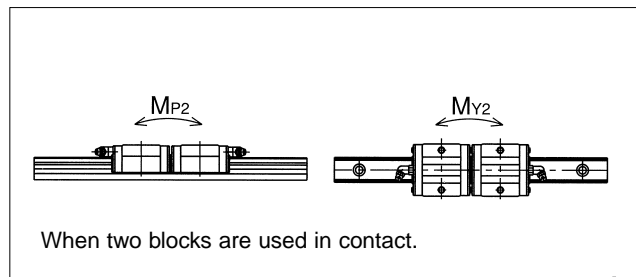

# SGL-TF TYPE

– High Rigidity Non-Flange Type –

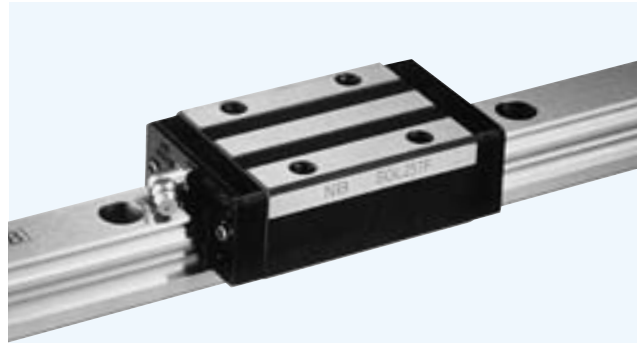

**part number structure**

example **SGL 15 TF B 2 T1 -589 D P / W2 RD F J**

SGL type

size

block style

seal

blank	with side-seals
B	seals on both ends + under-seals
BW	Double-seals on both ends + under-seals
BS	B + scraper

number of blocks per rail

symbol for pre-load

blank	standard
T1	light
T2	medium

with bellows with rail mounting hole caps

with Raydent treatment

symbol for number of rails

blank	single rail
W2	double rails
W3	triple rails

accuracy grade

blank	standard
H	high
P	precision

size of rail installation hole

total length of rail

Note: The symbol for the number of rail does not mean the number of rails ordered.

part number	assembly dimensions		block dimensions															
	H	W	B	L <sub>1</sub>	L <sub>2</sub>	L <sub>3</sub>	L <sub>4</sub>	P <sub>1</sub>	P <sub>2</sub>	S <sub>1</sub>	∅	T	b	E <sub>1</sub>	E <sub>2</sub>	T <sub>1</sub>	grease fitting	
	mm	mm	mm	mm	mm	mm	mm	mm	mm		mm	mm	mm	mm	mm	mm	mm	
<b>SGL15TF</b> <b>SGL15TF-D</b>	24	9.5	34	56.5	38.5	62.7	63.1	26	26	M4	7	6	19.5	6	5.4	5	pressed fitting	
<b>SGL20TF</b>	28	11	42	65.8	47.4	72	72.4	32	32	M5	8	7.5	22	14	13.3	6	B-M6F	
<b>SGL25TF</b>	33	12.5	48	80.2	59	86.4	87.2	35	35	M6	9	8	26		13.1	6.5		
<b>SGL30TF</b>	42	16	60	95.7	67.7	104.3	103.3	40	40	M8	12	9	32.5		9			
<b>SGL35TF</b>	48	18	70	109	78	117.6	116.6	50	50			13	38	14.0	8.5			

part number	standard rail length															
	L mm															
<b>SGL15</b>	160	220	280	340	400	460	520	580	640	700	760	820	880	940	1,000	
<b>SGL20</b>	220	280	340	400	460	520	580	640	700	760	820	880	940	1,000	1,120	
<b>SGL25</b>	220	280	340	400	460	520	580	640	700	760	820	880	940	1,000	1,120	
<b>SGL30</b>	280	360	440	520	600	680	760	840	920	1,000	1,080	1,160	1,240	1,320	1,400	
<b>SGL35</b>	280	360	440	520	600	680	760	840	920	1,000	1,080	1,160	1,240	1,320	1,400	

Rails exceeding the maximum specified length may be fabricated if joints are used. Contact NB for assistance.

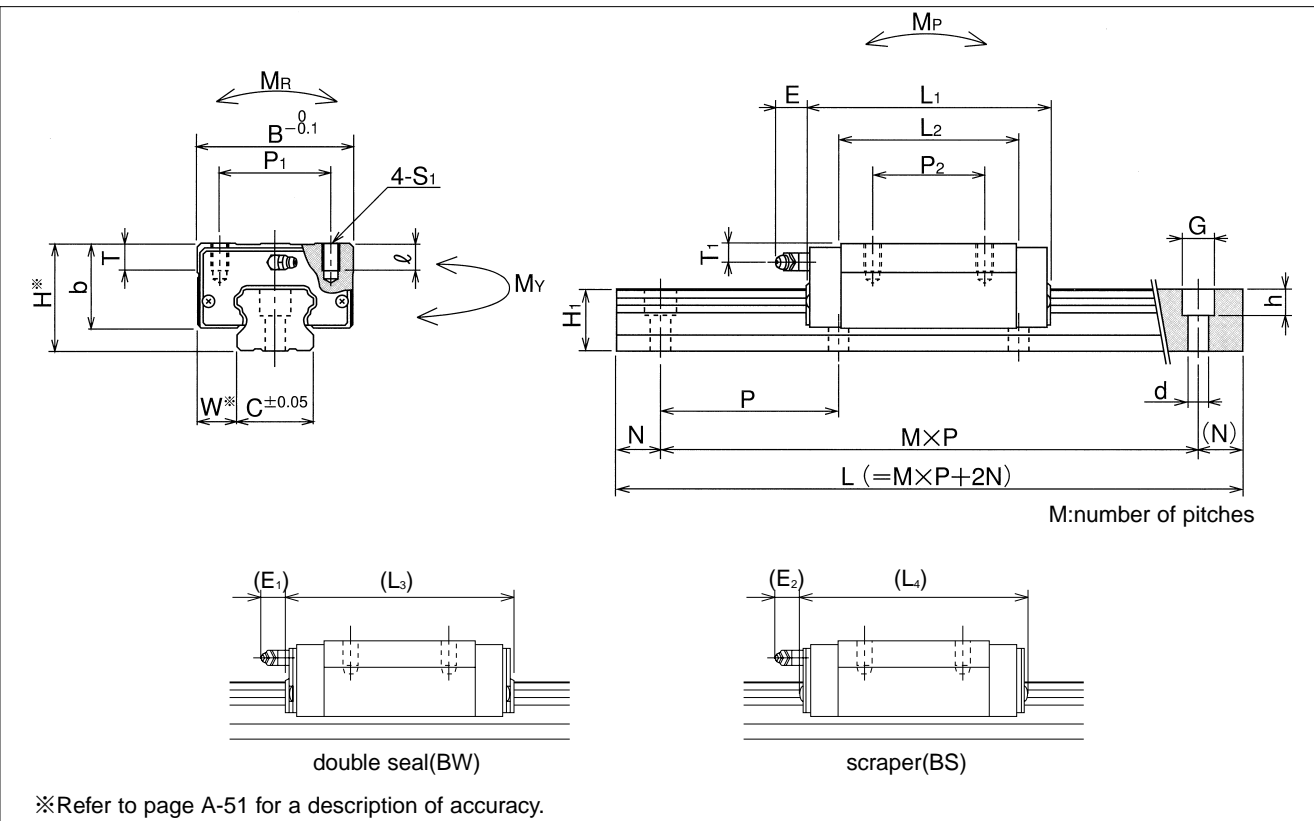

guide-rail dimensions					basic load rating		allowable static moment			mass		size	
H <sub>1</sub>	C	d × G × h	N	P	dynamic C	static C <sub>0</sub>	M <sub>P</sub>	M <sub>V</sub>	M <sub>R</sub>	block kg	guide rail kg/m		
mm	mm	mm	mm	mm	kN	kN	N · m	N · m	N · m	kg	kg/m		
13.5	15	3.5 × 6 × 4.5	20	60	8.6	14.2	69	69	98	0.2	1.3	<b>15</b>	
		4.5 × 7.5 × 5.3			12.7	21.6	157	157	235	0.3	2.1	<b>20</b>	
6 × 9.5 × 8.5	20.1	34.3			274	274	392	0.4	3.0	<b>25</b>			
24	28	7 × 11 × 9			80	23.5	39.7	314	314	549	0.8	4.6	<b>30</b>
						27.5	34	9 × 14 × 12	37.7	61.3	637	637	1,080

1kN ≒ 102kgf    1N·m ≒ 0.102kgf·m

							maximum length mm
1,120	1,240	1,360	1,480				2,000
1,240	1,360	1,480	1,600	1,720	1,840	1,960	3,000
1,240	1,360	1,480	1,600	1,720	1,840	1,960	3,000
1,480	1,640	1,720	1,800	1,960			3,000
1,480	1,640	1,720	1,800	1,960			3,000

# SGL-HTF TYPE

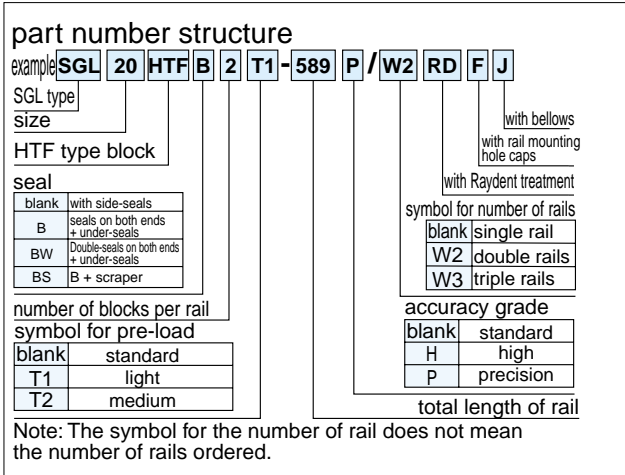
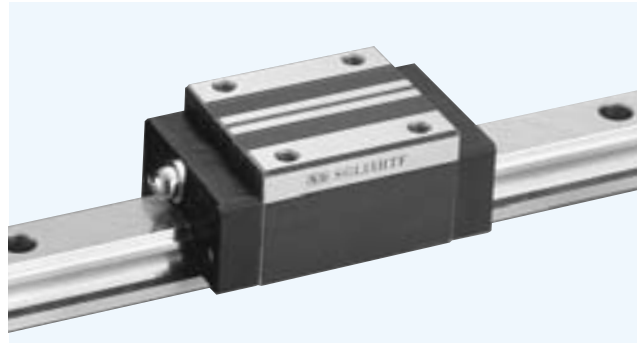

part number	assembly dimensions		block dimensions														
	H	W	B	L <sub>1</sub>	L <sub>2</sub>	L <sub>3</sub>	L <sub>4</sub>	P <sub>1</sub>	P <sub>2</sub>	S <sub>1</sub>	∅	T	b	E <sub>1</sub>	E <sub>2</sub>	T <sub>1</sub>	grease fitting
	mm	mm	mm	mm	mm	mm	mm	mm	mm		mm	mm	mm	mm	mm	mm	
<b>SGL15HTF</b>	28	9.5	34	56.5	38.5	62.7	63.1	26	26	M4	5	6	23.7	6	5.4	9	pressed fitting
<b>SGL20HTF</b>	30	12	44	71.6	53.2	77.8	78.2	32	36	M5	6	9.5	24	14	13.3	8	B-M6F
<b>SGL25HTF</b>	40	12.5	48	80	59	86.4	87.2	35	35	M6	8	9	33		13.1	13.5	
<b>SGL30HTF</b>	45	16	60	95.7	67.7	104.3	103.3	40	40	M8	10		35.5		14.0	12	
<b>SGL35HTF</b>	55	18	70	109	78	117.6	116.6	50	50		12	13	45			15.5	

part number	standard rail length														
	L mm														
<b>SGL15</b>	160	220	280	340	400	460	520	580	640	700	760	820	880	940	1,000
<b>SGL20</b>	220	280	340	400	460	520	580	640	700	760	820	880	940	1,000	1,120
<b>SGL25</b>	220	280	340	400	460	520	580	640	700	760	820	880	940	1,000	1,120
<b>SGL30</b>	280	360	440	520	600	680	760	840	920	1,000	1,080	1,160	1,240	1,320	1,400
<b>SGL35</b>	280	360	440	520	600	680	760	840	920	1,000	1,080	1,160	1,240	1,320	1,400

Rails exceeding the maximum specified length may be fabricated if joints are used. Contact NB for assistance.

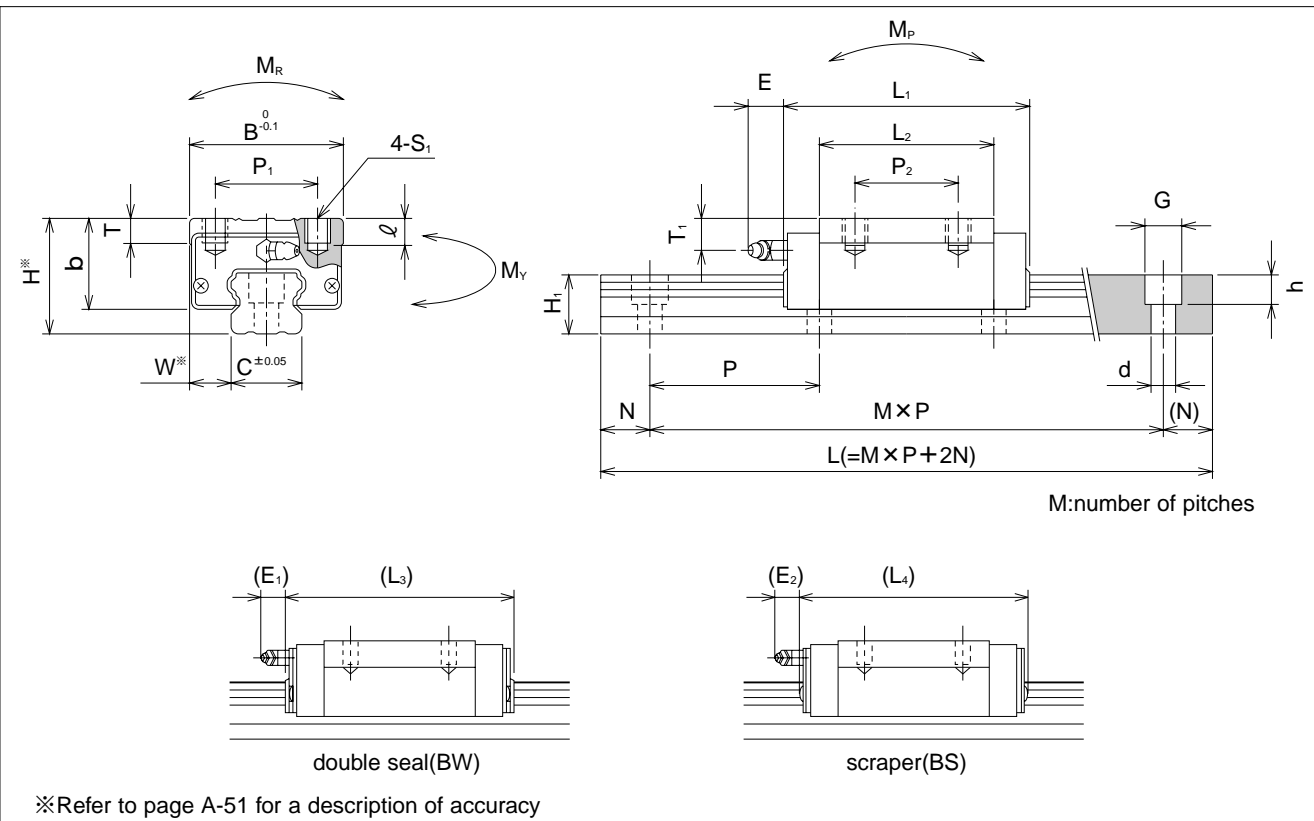

guide-rail dimensions					basic load rating		allowable static moment			mass		size
H <sub>1</sub>	C	d × G × h	N	P	dynamic C	static C <sub>0</sub>	M <sub>P</sub>	M <sub>V</sub>	M <sub>R</sub>	block kg	guide rail kg/m	
mm	mm	mm	mm	mm	kN	kN	N · m	N · m	N · m			
13.5	15	4.5 × 7.5 × 5.3	20	60	8.6	14.2	69	69	98	0.2	1.3	<b>15</b>
16	20	6 × 9.5 × 8.5			12.7	21.6	157	157	235	0.4	2.1	<b>20</b>
20	23	7 × 11 × 9			20.1	34.3	274	274	392	0.6	3.0	<b>25</b>
24	28	9 × 14 × 12		80	23.5	39.7	314	314	549	0.9	4.6	<b>3.0</b>
27.5	34				37.7	61.3	637	637	1,080	1.5	6.2	<b>35</b>

1kN ≒ 102kgf    1N·m ≒ 0.102kgf·m

							maximum length mm
1,120	1,240	1,360	1,480				2,000
1,240	1,360	1,480	1,600	1,720	1,840	1,960	3,000
1,240	1,360	1,480	1,600	1,720	1,840	1,960	3,000
1,480	1,640	1,720	1,800	1,960			3,000
1,480	1,640	1,720	1,800	1,960			3,000

# SGL-E TYPE

– High Rigidity Flange Type – (Short Configuration)

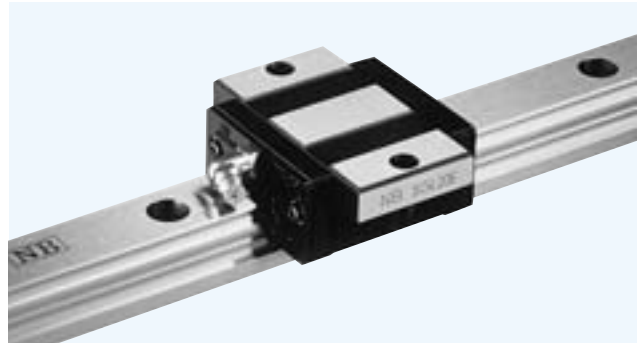

**part number structure**

example **SGL 15 E B 2 T1 - 589 D P / W2 RD F J**

SGL type	size	block style	seal	number of blocks per rail	symbol for pre-load	size of rail installation hole	total length of rail	with bellows	with rail mounting hole caps	with Raydent treatment	symbol for number of rails	accuracy grade
			blank with side-seals B seals on both ends + under-seals BW Double-seals on both ends + under-seals BS B + scraper		blank standard T1 light T2 medium						blank single rail W2 double rails W3 triple rails	blank standard H high P precision

Note: The symbol for the number of rail does not mean the number of rails ordered.

part number	assembly dimensions		block dimensions													
	H	W	B	L <sub>1</sub>	L <sub>2</sub>	L <sub>3</sub>	L <sub>4</sub>	P <sub>1</sub>	S <sub>1</sub>	T	b	E <sub>1</sub>	E <sub>2</sub>	T <sub>1</sub>	grease fitting	
<b>SGL15E</b> <b>SGL15E-D</b>	mm	mm	mm	mm	mm	mm	mm	mm	mm	mm	mm	mm	mm	mm	mm	pressed fitting
<b>SGL20E</b>	24	18.5	52	40.7	22.7	46.9	47.3	41	4.5	7	19.5	6	5.4	5	B-M6F	
<b>SGL25E</b>	28	19.5	59	47.9	29.5	54.1	54.5	49	5.5	9	22	14	13.3	6		
<b>SGL30E</b>	33	25	73	58.9	37.7	65.1	65.9	60	7	10	26		13.1	6.5		
<b>SGL35E</b>	42	31	90	68	40	76.6	75.6	72	9		13	32.5	14.0	9		
	48	33	100	77	46	85.6	84.6	82				38			8.5	

part number	standard rail length														
	L mm														
<b>SGL15</b>	160	220	280	340	400	460	520	580	640	700	760	820	880	940	1,000
<b>SGL20</b>	220	280	340	400	460	520	580	640	700	760	820	880	940	1,000	1,120
<b>SGL25</b>	220	280	340	400	460	520	580	640	700	760	820	880	940	1,000	1,120
<b>SGL30</b>	280	360	440	520	600	680	760	840	920	1,000	1,080	1,160	1,240	1,320	1,400
<b>SGL35</b>	280	360	440	520	600	680	760	840	920	1,000	1,080	1,160	1,240	1,320	1,400

Rails exceeding the maximum specified length may be fabricated if joints are used. Contact NB for assistance.

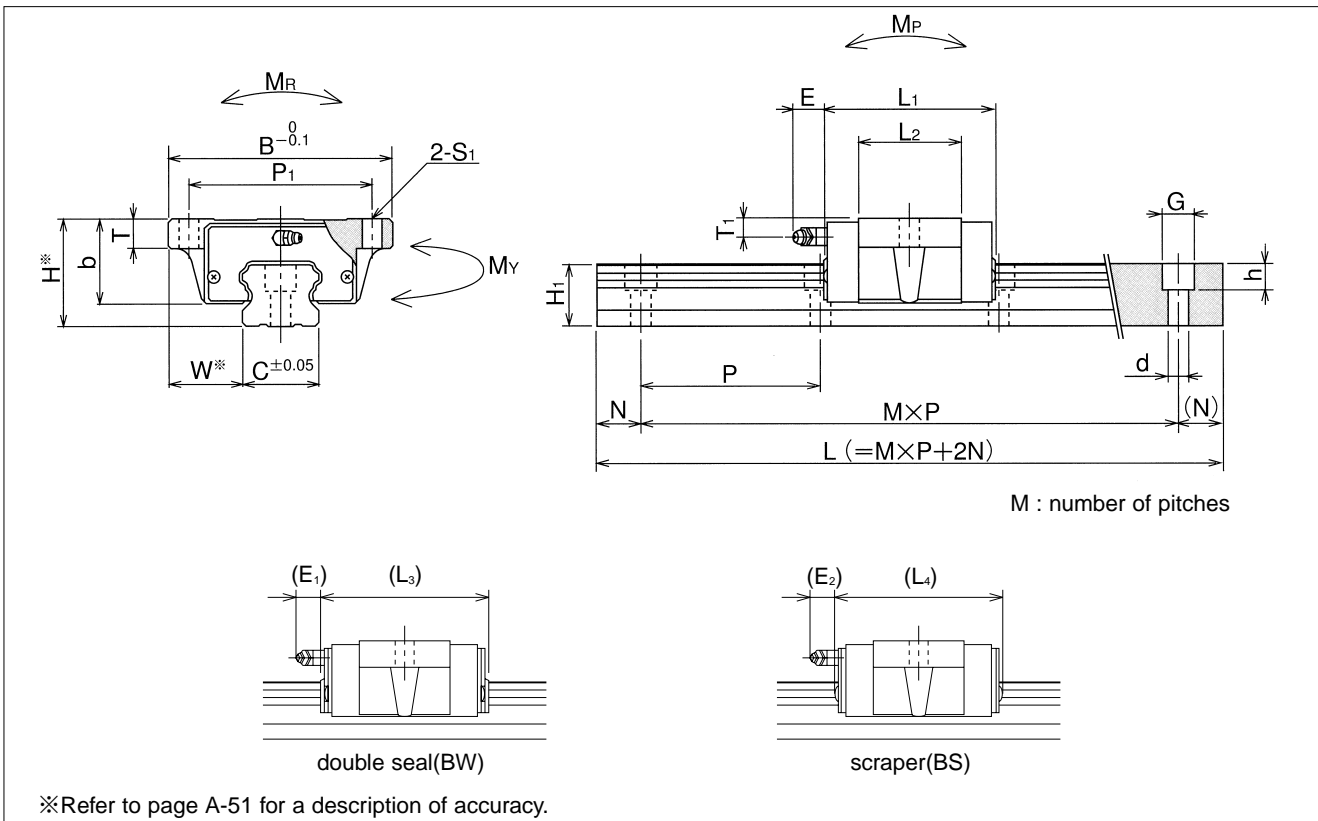

guide-rail dimensions					basic load rating		allowable static moment			mass		size
H <sub>i</sub>	C	d×G×h	N	P	dynamic C	static C <sub>0</sub>	M <sub>P</sub>	M <sub>Y</sub>	M <sub>R</sub>	block	guide rail	
mm	mm	mm	mm	mm	kN	kN	N·m	N·m	N·m	kg	kg/m	
13.5	15	3.5×6×4.5	20	60	5	8.23	33	33	57	0.1	1.3	15
		4.5×7.5×5.3					196	196				
16	20	6×9.5×8.5			7.35	12.3	59	59	137	0.2	2.1	20
20	23	7×11×9			11.7	19.6	109	109	225	0.4	3.0	25
24	28				652	652	319	0.6	4.6	30		
27.5	34	9×14×12			13.7	22.5	123	123	319	0.6	4.6	30
			21.6	35.7	248	248	627	0.9	6.2	35		

1kN ≒ 102kgf    1N·m ≒ 0.102kgf·m

							maximum length mm
1,120	1,240	1,360	1,480				2,000
1,240	1,360	1,480	1,600	1,720	1,840	1,960	3,000
1,240	1,360	1,480	1,600	1,720	1,840	1,960	3,000
1,480	1,640	1,720	1,800	1,960			3,000
1,480	1,640	1,720	1,800	1,960			3,000

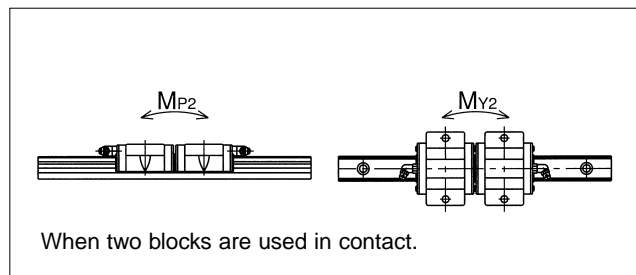

# SGL-TE TYPE

– High Rigidity Flange Type –

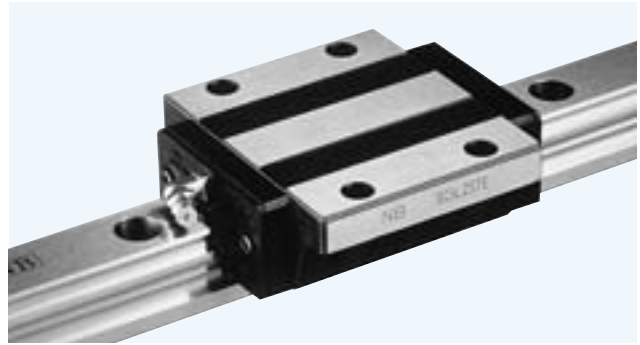

**part number structure**

example **SGL 15 TE B 2 T1 -589 D P / W2 RD F J**

SGL type	size	block style	seal	number of blocks per rail	symbol for pre-load	accuracy grade	symbol for number of rails	size of rail installation hole	total length of rail
			blank B BW BS	blank T1 T2	blank H P	blank H P	blank W2 W3	with bellows with rail mounting hole caps with Raydent treatment	
			with side-seals seals on both ends + under-seals Double-seals on both ends + under-seals B + scraper		standard light medium	standard high precision	single rail double rails triple rails		

Note: The symbol for the number of rail does not mean the number of rails ordered.

part number	assembly dimensions		block dimensions														
	H	W	B	L <sub>1</sub>	L <sub>2</sub>	L <sub>3</sub>	L <sub>4</sub>	P <sub>1</sub>	P <sub>2</sub>	S <sub>1</sub>	T	b	E <sub>1</sub>	E <sub>2</sub>	T <sub>1</sub>	grease fitting	
	mm	mm	mm	mm	mm	mm	mm	mm	mm	mm	mm	mm	mm	mm	mm	mm	
<b>SGL15TE</b> <b>SGL15TE-D</b>	24	18.5	52	56.5	38.5	62.7	63.1	41	26	4.5	7	19.5	6	5.4	5	pressed fitting	
<b>SGL20TE</b>	28	19.5	59	65.8	47.4	72	72.4	49	32	5.5	9	22	14	13.3	6	B-M6F	
<b>SGL25TE</b>	33	25	73	80.2	59	86.4	87.2	60	35	7	10	26		13.1	6.5		
<b>SGL30TE</b>	42	31	90	95.7	67.7	104.3	103.3	72	40	9	13	32.5		14.0	9		
<b>SGL35TE</b>	48	33	100	109	78	117.6	116.6	82	50			13		38	14.0		8.5

part number	standard rail length														
	L mm														
<b>SGL15</b>	160	220	280	340	400	460	520	580	640	700	760	820	880	940	1,000
<b>SGL20</b>	220	280	340	400	460	520	580	640	700	760	820	880	940	1,000	1,120
<b>SGL25</b>	220	280	340	400	460	520	580	640	700	760	820	880	940	1,000	1,120
<b>SGL30</b>	280	360	440	520	600	680	760	840	920	1,000	1,080	1,160	1,240	1,320	1,400
<b>SGL35</b>	280	360	440	520	600	680	760	840	920	1,000	1,080	1,160	1,240	1,320	1,400

Rails exceeding the maximum specified length may be fabricated if joints are used. Contact NB for assistance.

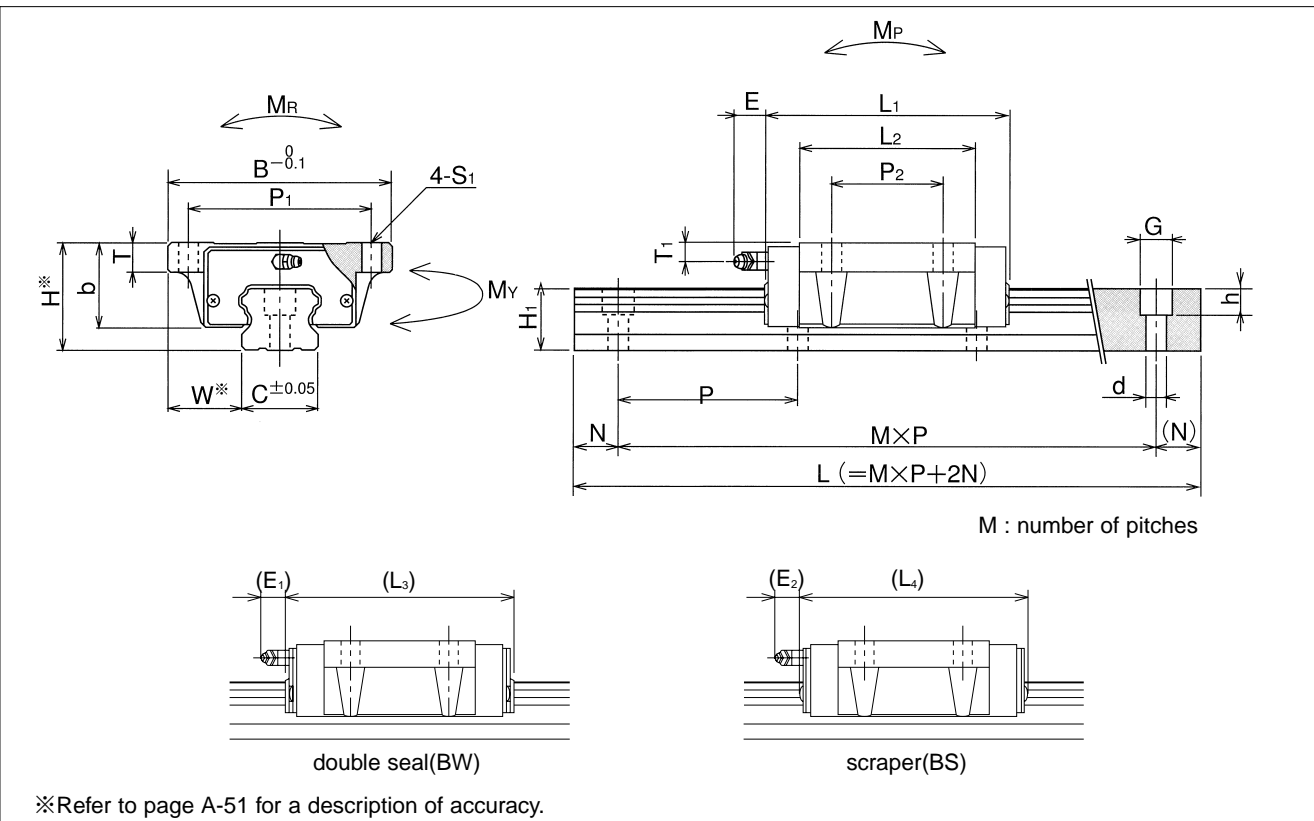

※Refer to page A-51 for a description of accuracy.

guide-rail dimensions					basic load rating		allowable static moment			mass		size	
$H_i$	C	$d \times G \times h$	N	P	dynamic C	static $C_0$	$M_P$	$M_Y$	$M_R$	block	guide rail		
mm	mm	mm	mm	mm	kN	kg	$N \cdot m$	$N \cdot m$	$N \cdot m$	kg	kg/m		
13.5	15	3.5×6×4.5	20	60	8.6	14.2	69	69	98	0.2	1.3	15	
		4.5×7.5×5.3			12.7	21.6							
16	20	6×9.5×8.5			20.1	34.3	274	274	392	0.6	3.0	25	
24	28	7×11×9			80	23.5	39.7	314	314	549	1.0	4.6	30
27.5	34	9×14×12				37.7	61.3	637	637	1,080	1.5	6.2	35

1kN ≒ 102kgf 1N·m ≒ 0.102kgf·m

							maximum length
							mm
1,120	1,240	1,360	1,480				2,000
1,240	1,360	1,480	1,600	1,720	1,840	1,960	3,000
1,240	1,360	1,480	1,600	1,720	1,840	1,960	3,000
1,480	1,640	1,720	1,800	1,960			3,000
1,480	1,640	1,720	1,800	1,960			3,000

# SGL-HTE TYPE

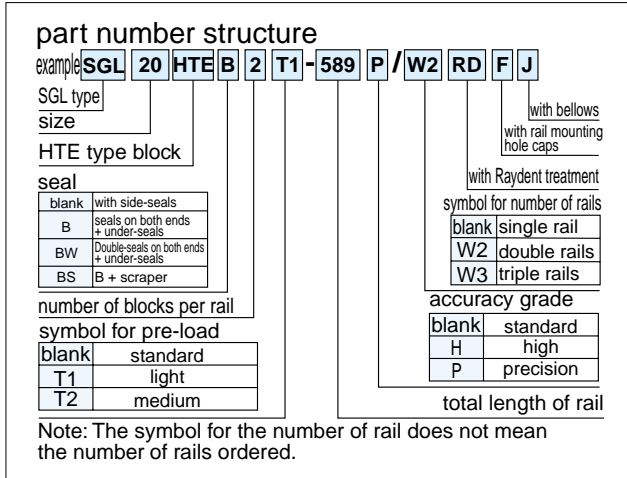
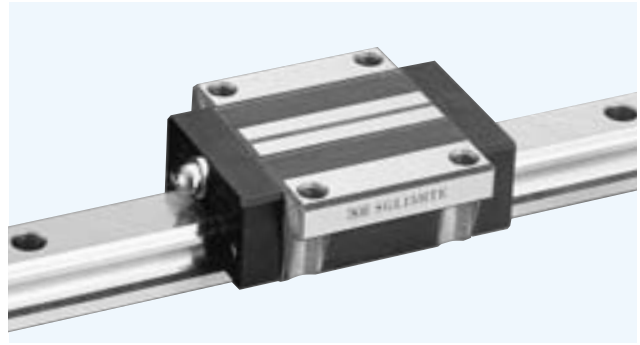

part number	assembly dimensions		block dimensions														
	H	W	B	L <sub>1</sub>	L <sub>2</sub>	L <sub>3</sub>	L <sub>4</sub>	P <sub>1</sub>	P <sub>2</sub>	S <sub>1</sub>	D	T	b	E <sub>1</sub>	E <sub>2</sub>	T <sub>1</sub>	grease fitting
	mm	mm	mm	mm	mm	mm	mm	mm	mm		mm	mm	mm	mm	mm	mm	
<b>SGL15HTE</b>	24	16	47	56.5	38.5	62.7	63.1	38	30	M5	4.4	7	19.7	6	5.4	5	pressed fitting
<b>SGL20HTE</b>	30	21.5	63	71.6	53.2	77.8	78.2	53	40	M6	5.4	10.5	24	14	13.3	8	B-M6F
<b>SGL25HTE</b>	36	23.5	70	80	59	86.4	87.2	57	45	M8	6.8	12.5	29		13.1	9.5	
<b>SGL30HTE</b>	42	31	90	95.7	67.7	104.3	103.3	72	52	M10	8.5	10	32.5		9		
<b>SGL35HTE</b>	48	33	100	109	78	117.6	116.6	82	62			13	38		14.0	8.5	

part number	standard rail length															
	L mm															
<b>SGL15</b>	160	220	280	340	400	460	520	580	640	700	760	820	880	940	1,000	
<b>SGL20</b>	220	280	340	400	460	520	580	640	700	760	820	880	940	1,000	1,120	
<b>SGL25</b>	220	280	340	400	460	520	580	640	700	760	820	880	940	1,000	1,120	
<b>SGL30</b>	280	360	440	520	600	680	760	840	920	1,000	1,080	1,160	1,240	1,320	1,400	
<b>SGL35</b>	280	360	440	520	600	680	760	840	920	1,000	1,080	1,160	1,240	1,320	1,400	

Rails exceeding the maximum specified length may be fabricated if joints are used. Contact NB for assistance.

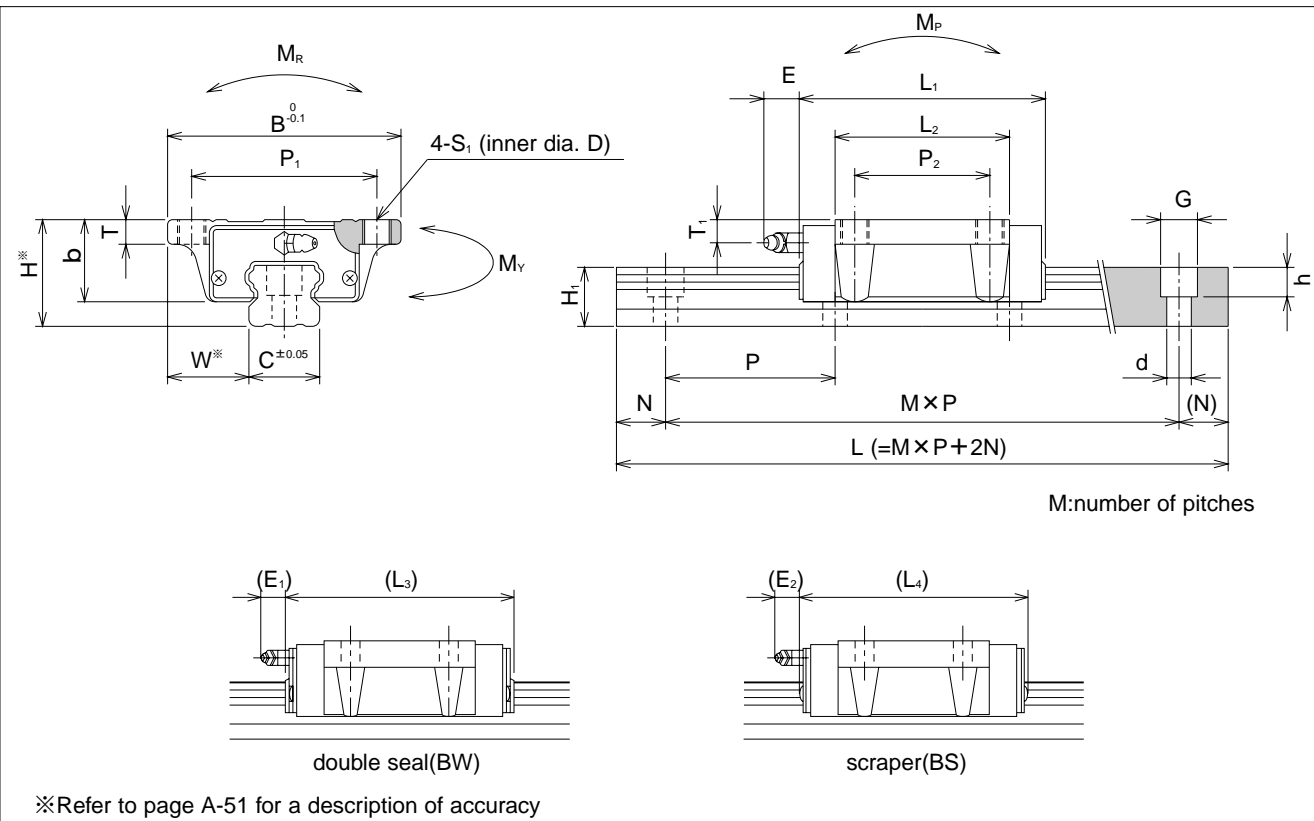

guide-rail dimensions					basic load rating		allowable static moment			mass		size
H <sub>1</sub>	C	d × G × h	N	P	dynamic C	static C <sub>0</sub>	M <sub>P</sub>	M <sub>V</sub>	M <sub>R</sub>	block kg	guide rail kg/m	
mm	mm	mm	mm	mm	kN	kN	N · m	N · m	N · m			
13.5	15	4.5 × 7.5 × 5.3	20	60	8.6	14.2	69	69	98	0.2	1.3	<b>15</b>
16	20	6 × 9.5 × 8.5			12.7	21.6	157	157	235	0.4	2.1	<b>20</b>
20	23	7 × 11 × 9			20.1	34.3	274	274	392	0.6	3.0	<b>25</b>
24	28	9 × 14 × 12		80	23.5	39.7	314	314	549	1.0	4.6	<b>30</b>
27.5	34				37.7	61.3	637	637	1,080	1.5	6.2	<b>35</b>

1kN ≒ 102kgf    1N·m ≒ 0.102kgf·m

							maximum length mm
1,120	1,240	1,360	1,480				2,000
1,240	1,360	1,480	1,600	1,720	1,840	1,960	3,000
1,240	1,360	1,480	1,600	1,720	1,840	1,960	3,000
1,480	1,640	1,720	1,800	1,960			3,000
1,480	1,640	1,720	1,800	1,960			3,000