

GONIO WAY

The NB Gonio way is a curved SV type slide way. It is a curved motion bearing utilizing low-friction, non-recirculating, precision cross-rollers. It is used when there is a need to change the gradient or obtain an accurate gradient angle without changing the center of rotation in high-precision optical and measurement equipment.

STRUCTURE AND ADVANTAGES

The NB Gonio way consists of hardened curved tracking bases with precisely machined V-grooves and a curved roller cage with cross-rollers. High-precision rollers are used as the rotating elements. Since the rotational elements do not recirculate, there is less friction fluctuation, resulting in a low-frictional curved motion.

Suitable for Minute Motion:

The frictional resistance is extremely small and there is little or no difference between the static and dynamic frictional resistance. The NB Gonio slide way is well suited for minute motion. It can follow minute motion accurately, resulting in highly accurate curved motion.

High Rigidity and High Load Capacity:

The rollers provide a larger contact area than ball elements and there is less elastic deformation. Additionally, since the rollers do not recirculate, the effective number of rotating elements is larger, resulting in high rigidity and high load capacity.

Ease of Assembly and Installation:

The rollers are retained inside a curved roller cage, allowing assembly, installation, and the handling of components simplified. A set of components consists of 4 curved tracking bases, 2 curved roller cages, and 8 end pieces. It can be assembled immediately.

Low Noise:

The use of a roller cage prevents noise from being generated by contact between the rotating elements, resulting in quiet operation.

Figure H-23 Structure of RV Type Gonio Way

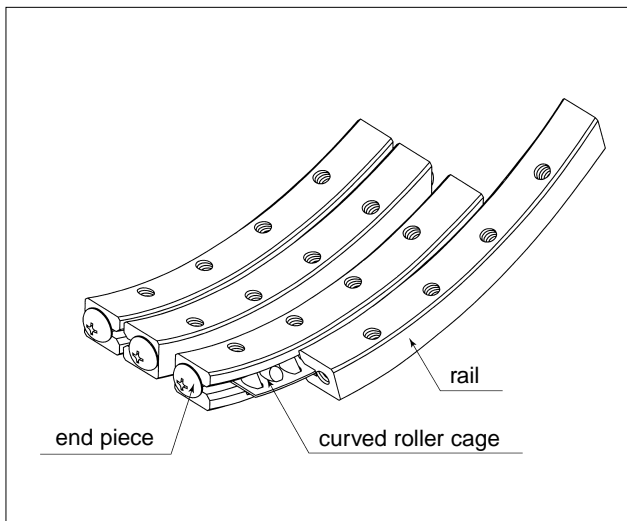

ACCURACY

The accuracy of a Gonio way is measured along its over all length, as shown in Figure H-24.

Table H-12 Accuracy unit/ μm

part number	accuracy
RV2040-50	10
RV2060-60	10
RV3070-90	10
RV3070-110	10
RV3100-160	10

The reference surfaces are located on the opposite side of the “NB” mark.

There are inner reference plane and outer reference planes in one set of RV.

Figure H-24 Accuracy Measurement

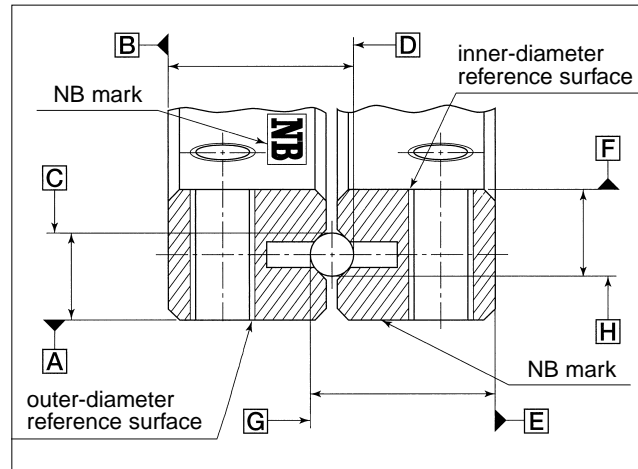

LIFE CALCULATION

The life of a Gonio way is obtained using the following equations.

Travel life:

$$L = \left(\frac{f_T}{f_w} \cdot \frac{C}{P} \right)^{10/3} \cdot 50$$

L : travel life (km) f_T : temperature coefficient f_w : load coefficient
C : basic dynamic load rating (N) P : applied load (N)

※ Refer to page Eng. 5 for the coefficients.

Life time:

$$L_H = \frac{L \cdot 10^3}{2 \cdot \ell_s \cdot n_1 \cdot 60}$$

L_H : life time (hr) ℓ_s : stroke (m)
 n_1 : strokes frequency per min. (cpm)

MOUNTING

Figure H-25 Example of Mounting

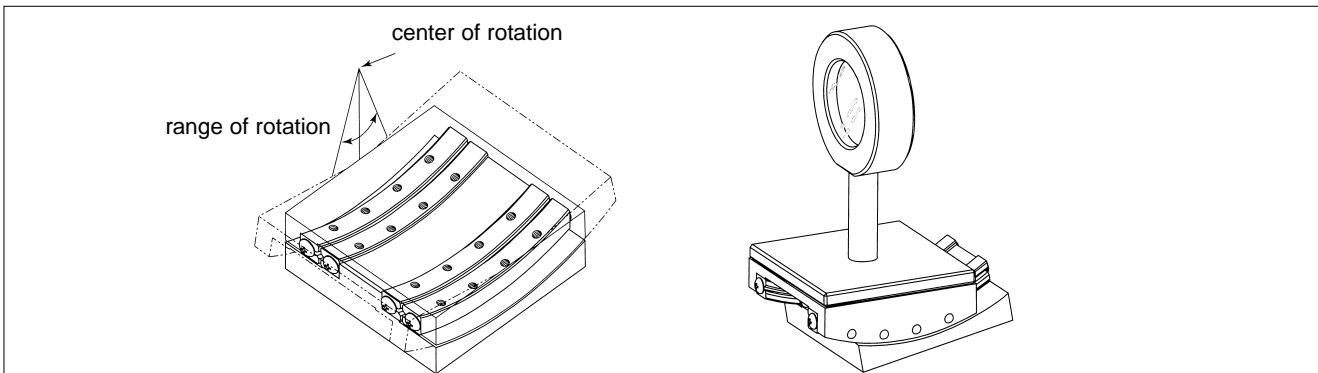

Accuracy of Mounting Surfaces:

The accuracy of the mounting should be maintained as needed for the operation. The accuracy of surfaces 1, 2, 3, and 4 (Figure H-26) directly affect the motion accuracy. They should be sufficient for the intended operation.

Figure H-26 Accuracy of Installation Surfaces

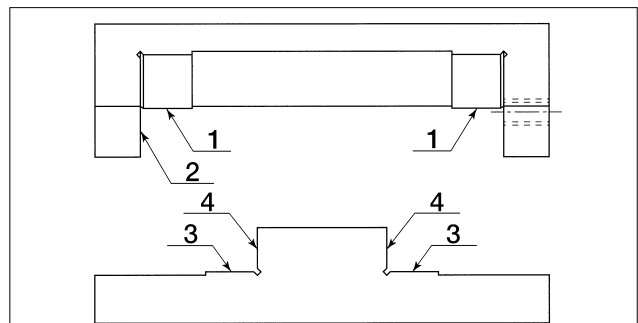

Procedure (refer to Figure H-27):

- (1) Remove burrs, dirt, dust, etc. from the table and the installation surfaces of the bed.
- (2) Apply a low viscosity oil to contact surfaces. Fix the rail ① ② and ③ by tightening bolts to specified torque values (Figure H-27a).
- (3) Temporarily attach the rail ④ on curved tracking base to the adjustment side (Figure H-27b).
- (4) Remove the end pieces on one side of the rails and insert roller cages to the center (Figure H-27c).

Figure H-27 Mounting Method (1)

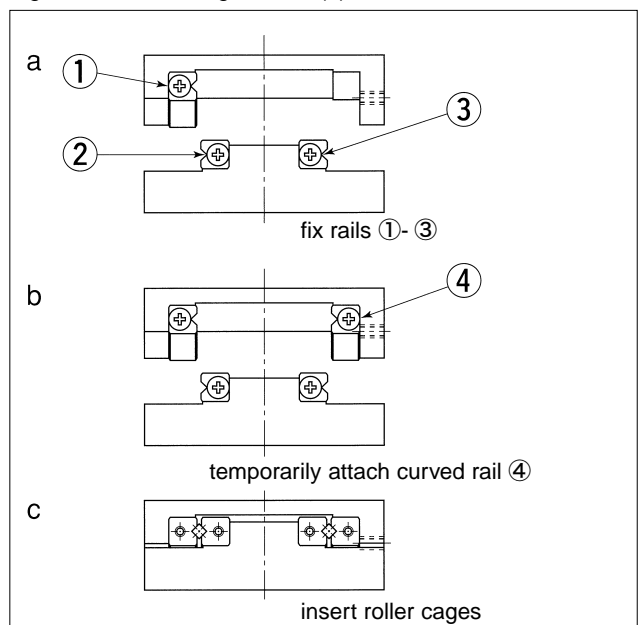

- (5) Re-attach end-pieces.
- (6) Move table to the right and left (in the direction of the stroke) to position roller cages at the center of the curved rails.
- (7) Set an indicator at the side of the table on the reference surface (Figure H-28d).
- (8) Move table to one of the stroke ends and tighten the adjustment screws slightly. Figure H-28e).
- (9) Move table fully to the other stroke end and tighten the adjustment screws slightly. (Figure H-28f).
- (10) Move the table to the center and lightly tighten adjustment screws (Figure H-28g).
- (11) Repeat steps (8) ~ (10) until there is no clearance around the table. If there is no clearance, the indicator will show a minimum fluctuation value when the table is moved to the right and left. Exercise care so as not to apply an excessive amount of pre-load.
- (12) Repeat steps (8) ~ (10) and tighten the adjustment screws uniformly.
- (13) Fix the rail ④. Tighten the roller cage bolts sequentially by moving the table in the same manner as for tightening the adjustment screws.

Figure H-28 Mounting Method (2)

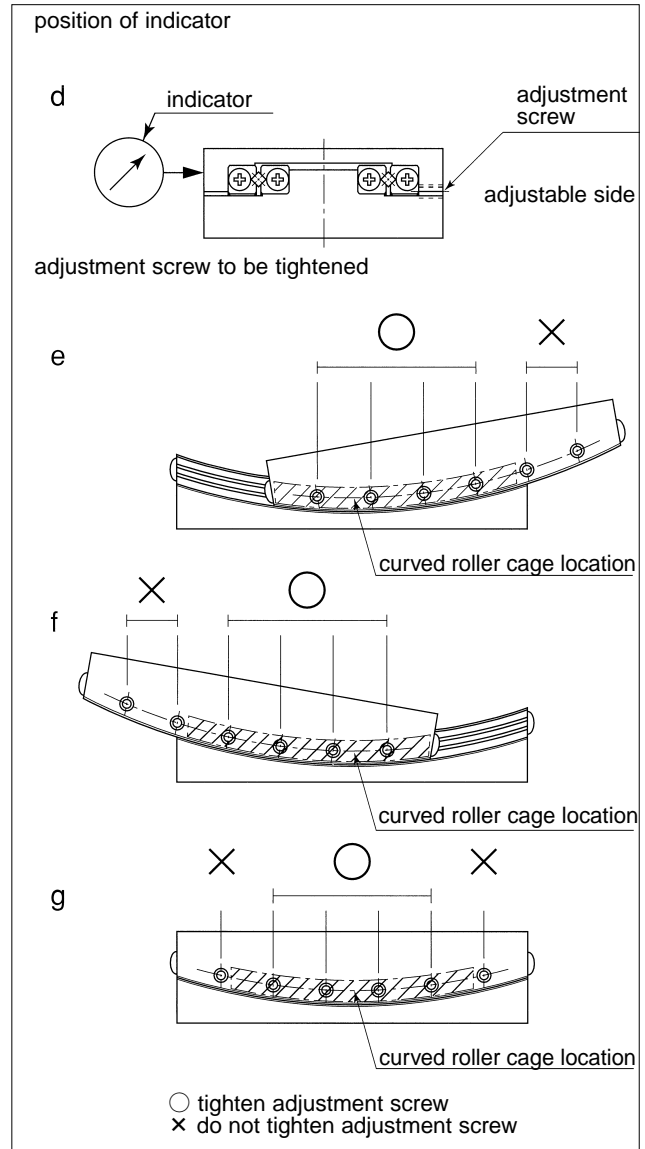

Table H-13 Recommended Torque for Installation Bolts unit/N • m

part number	bolt size	torque
RV2	M3	2
RV3		

NOTES ON INSTALLATION

Lubrication:

NB Gonio slide ways are pre-lubricated using lithium soap grease prior to shipment, so they can be used immediately. Periodic application of a similar type grease is recommended depending on the operating conditions.

Dust Prevention:

Dust and foreign particles can affect the accuracy and life of a Gonio slide way. A table used in a hostile environment should be protected with a cover.

Operating Temperature:

The operating temperature should be kept between -20°C and 110°C.

Pre-load Adjustment:

Inaccurate pre-load adjustment will reduce the motion accuracy, resulting in skewing and shortening life. Careful adjustment is a requirement.

Cage Slippage:

When used under high speeds, or unbalanced loads, or when vibration condition are present, the roller cage slippage may occur. The rotation range should be determined with a sufficient margin, and an excessive pre-load should not be applied.

End Pieces:

End pieces are attached to each end of the rail to prevent removal of the cage. Do not use them as a mechanical stopper.

Careful Handling:

Dropping a Gonio slide way may result in scratches or dents on the raceway surfaces, preventing smooth motion and affecting accuracy. Care should be exercised in handling.

Use as a Set:

The accuracy tolerance of a Gonio slide way is designed to be adjusted within a particular set of components. If components from different sets are used, the accuracy may be affected.

SPECIAL REQUIREMENTS

NB can fabricate Gonio slide ways to meet special requirements, including slide ways with non-standard roller sizes, curved tracking base lengths, rotation center diameters, rotation ranges, and number of rollers. Contact NB for further information.

RV TYPE

— Gonio Way —

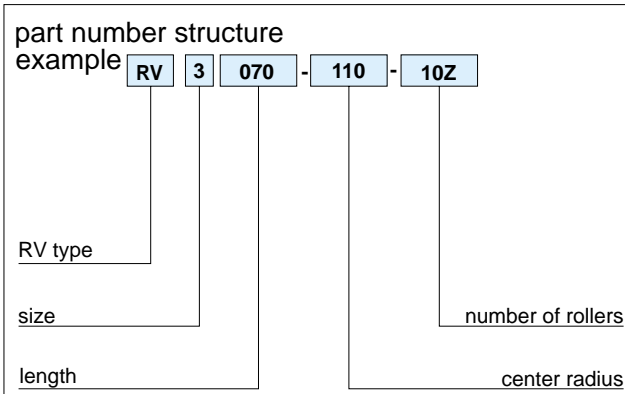
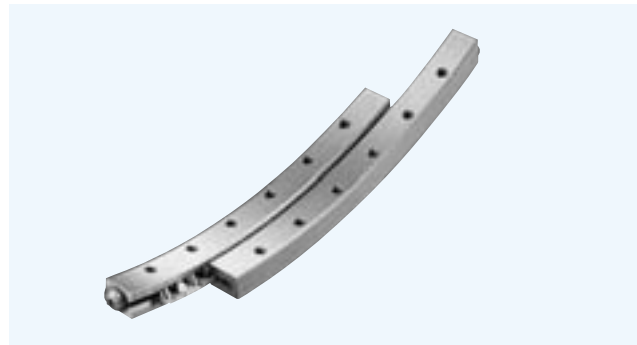

part number	rotation range	roller diameter D mm	No. of rollers Z	major dimensions						
				L mm	R mm	R ₁ mm	R ₂ mm	A mm	B mm	C mm
RV2040- 50- 7Z	±10°	2	7	40	50	53	47	15	6	7.25
RV2060- 60-12Z			12	60	60	63	57			
RV3070- 90-11Z	±10°	3	11	70	90	94	86	18	8	8.5
RV3070-110-10Z			10	70	110	114	106			
RV3100-160-14Z			14	100	160	164	156			

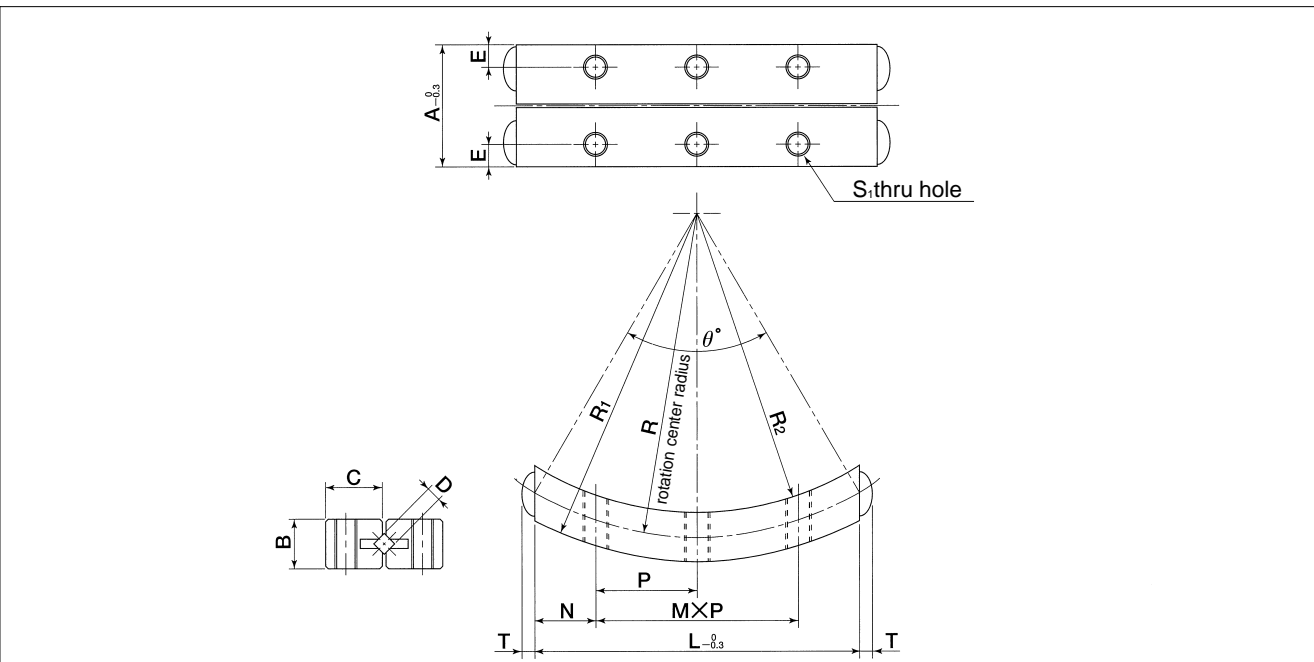

※ One set consists of 4 curved rails, 2 curved roller cages, and 8 end pieces.

M×P mm	N mm	E mm	S ₁	T mm	θ	basic load rating		mass g	part number
						dynamic C N	static Co N		
2×12.5	7.5	2.5	M3	1.5	47.2°	802	878	49	RV2040- 50 7Z
3×12.5	11.25				60.0°	1,176	1,464	75	RV2060- 60-12Z
3×15	12.5	3	M3	1.9	45.8°	2,632	3,516	137	RV3070- 90-11Z
3×15					37.1°	2,632	3,516	135	RV3070-110-10Z
5×15					36.4°	3,388	4,923	193	RV3100-160-14Z