

# ***UMETA***

UMETA products are available from  
MARYLAND METRICS  
P.O. Box 261 Owings Mills, MD 21117 USA  
ph: (410)358-3130 (800)638-1830 fx: (410)358-3142 (800)872-9329

web: <http://mdmetric.com> email: [sales@mdmetric.com](mailto:sales@mdmetric.com)  
RFQ form: <http://mdmetric.com/rfq.htm>

UMETA Hermann Ulrichskötter  
Metallwarenfabrik GmbH & Co. KG

Almestraße 1-3 · 33649 Bielefeld · Germany  
Fon: +49 (0)521.948-0 · Fax: +49 (0)521.948-111

***We make it move.***

# ***UMETA***

## **DRP 30**



***We make it move.***

## **D** Druckluftfettpresse DRP 30

- automatische Dauerförderung
- mit DIN-Befüllnippel und Entlüftungsventil im Pressenkopf
- Druckluftanschluss für Schnellkupplung
- besonders leicht und handlich durch Aluminiumgehäuse mit ergonomischem Handgriff
- Anschlussgewinde R 1/8
- inklusive 300 mm langem Hochdruckschlauch Ø 13 mm und Düsenrohr, jeweils mit Hydraulikgreifkupplung

### Technische Daten

Einsatz:	Schmierfette, bis NLGI 2
Füllmenge:	400 g Fettkartusche oder 500 g loses Fett (Fettfüllgerät)
Druckverhältnis:	40:1
Eingangsluftdruck:	3-7 bar, empfohlener Druck
Förderdruck:	6 bar
	280 bar max.

## **GB** Air operated grease gun DRP 30

- continuous grease flow
- separate filling nipple and ventilation valve
- compressed air connection for quick coupler
- extra light and handy by aluminium body
- connection thread R 1/8
- complete with high-pressure hose 300 mm, Ø 13 mm, and extension tube, each with hydraulic coupler

### Technical Data

Application:	suitable for grease up to NLGI 2
Filling capacity:	400 g cartridge or 500 g bulk grease
Pressure ratio:	40:1
Air pressure ratio:	3-7 bar, 6 bar recommended
Operating pressure:	280 bar max.

## **F** Pompe à graisse à air comprimé DRP 30

- Approvisionnement continu automatique de la graisse
- Avec valve de remplissage et purge d'air
- Raccord pneumatique pour raccord rapide
- Particulièrement légère grâce à sa tête alu et maniable avec sa poignée ergonomique
- Raccord pour accessoires R 1/8
- Livrée avec 300 mm flexible, Ø 13 mm, longueur et rigide, tous deux avec agrafe hydraulique

### Données techniques

Appropriée:	aux graisses de classe NLGI 2
Remplissage:	cartouche de 400 g ou 500 g de graisse en vrac
Rapport de compression:	40:1
Pression d'air:	3-7 bar, recommandée 6 bar
Pression:	280 bar max.

## **ES** Bomba de engrase neumática DRP 30

- Suministro de grasa permanente
- engrasador de llenado y válvula de ventilación separados
- Adaptador rápido
- Cuerpo de aluminio muy ligero y ergonómico
- Rosca de conexión R 1/8
- Incl. latiguillo flexible 300 mm, Ø 13 mm, y lanza de extensión incluidos, respectivamente con embrague hidráulico

### Información Técnica

Apropiada para:	grasa de viscosidad hasta NLGI 2
Capacidad de almacenaje:	cartucho de grasa de 400 g ó bien 500 g de grasa suelta (aparato de llenado de grasa)
Tasa de compresión:	40:1
Tasa de compresión de aire:	3-7 bar, recomendado 6 bar
Presión de trabajo:	280 bar máx.

## **I** Ingrassatore a siringa azionato ad aria compressa DRP 30

- Alimentazione del grasso permanente
- Dotato di nipplo di riempimento a norma DIN e valvola di sfianto nella parte superiore dell'ingrassatore
- Attacco ad aria compressa
- Particolarmente leggero e maneggevole grazie al corpo in acciaio con maniglia ergonomica
- Attacco filettato R 1/8
- Incl. tubo flessibile per l'alta pressione di lunghezza 300 mm, Ø 13 mm e tubo per ugello, a due con l'accoppiamento idraulico

### Dati Tecnici

Idoneo per:	grassi lubrificanti fino a NLGI 2
Contenuto effettivo:	cartuccia di lubrificante da 400 g oppure 500 g di grasso sciolto
Rapporto di pressione:	40:1
Pressione dell'aria in entrata:	3-7 bar, pressione consigliata 6 bar
Pressione di mandata:	280 bar max.

## **NL** Pneumatische vetspuit DRP 30

- Vettransport/opbrengst door automatische, constante afgifte
- Met DIN-vulnippel en ontluftingsventiel in de perskop
- Lucht aansluiting voor snelkoppeling
- Bijzonder licht en handig door aluminium behuizing met ergonomisch handgreep
- Aansluiting R 1/8
- Inclusief 300 mm hogedruk slang Ø 13 mm, en sproeipijp met hydraulisch mondstuk

### Technische data

Geschikt voor:	Smeervetten tot NLGI 2
Vulcapaciteit:	400 g vetcartouche of 500 g los vet (vet vulapparaat)
Drukverhouding:	40:1
Luchtaansluiting:	3 - 7 bar, aanbevolen druk 6 bar
Drukopbrengst:	280 bar max.

## **Inhalt Contents · Contenu · Indice .....**

<b>D</b>	<b>Bedienungsanleitung zur Befüllung der DRP 30 mit Fettkartuschen</b>	<b>4</b>
	<b>Vorbereitung zur Befüllung der DRP 30 mit loseem Fett</b>	<b>5</b>
<b>GB</b>	<b>Instruction for filling the DRP 30 with grease cartridges</b>	<b>6</b>
	<b>Preparation for filling the DRP 30 with bulk grease</b>	<b>7</b>
<b>F</b>	<b>Instructions pour utilisation de la pompe DRP 30 avec cartouche de graisse</b>	<b>8</b>
	<b>Préparation avant utilisation de la pompe DRP 30 avec de la graisse en vrac</b>	<b>9</b>
<b>ES</b>	<b>Instrucciones para llenar la bomba DRP 30 con cartuchos de grasa</b>	<b>10</b>
	<b>Preparación para llenar la bomba DRP 30 con grasa a granel</b>	<b>11</b>
<b>I</b>	<b>Istruzioni per il riempimento del DRP 30 con la cartuccia di lubrificante</b>	<b>12</b>
	<b>Preparativi per il riempimento del DRP 30 con grasso sciolto</b>	<b>13</b>
<b>NL</b>	<b>Handleiding voor het vullen van de DRP 30 met een vetpatroon</b>	<b>14</b>
	<b>Vorbereiding vulling van de DRP 30 met los vet</b>	<b>15</b>

## D Bedienungsanleitung zur Befüllung der DRP 30 mit Fettkartuschen



- 1.** Für einen Wechsel der Fettkartusche das Pressenrohr abschrauben



- 5.**  
 1 Zugstange entlasten  
 2 Klemmhebel drücken  
 3 Zugstange in Pressenrohr zurückschieben



- 2.** Zugstange in Endposition zurückziehen



- 6.** Entlüften durch Drücken des Entlüftungsventils



- 3.** Fettkartusche einführen



- 7.** Zubehör (Düsenrohr oder Schlauch) aufschrauben



- 4.** Pressenrohr in Antriebseinheit einschrauben

## D Vorbereitung zur Befüllung der DRP 30 mit losem Fett



### Achtung

Zur Befüllung mit losem Fett wird dringend empfohlen, die Manschette im Pressenrohr umzudrehen. Halten Sie das Fettpressenrohr während des gesamten Umbauvorgangs mit der offenen Gewindeseite grundsätzlich von sich selbst und anderen Personen abgewandt! Im Zweifelsfall ziehen Sie immer einen Spezialisten zu Rate und beachten Sie unbedingt unsere Sicherheitshinweise auf [www.umeta.com](http://www.umeta.com)



- 1.** Pressenkopf entfernen und Zugstange (3) zurückziehen, bis der Klemmhebel (4) einrastet und somit die Zugstange fixiert. Dann erst den Kreuzgriff (1) und die Sicherungsmutter (2) von der Zugstange schrauben.

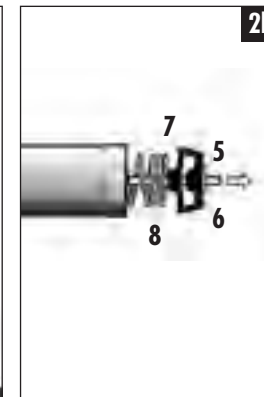
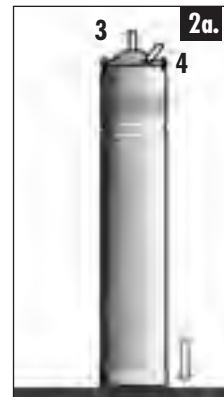

- 2.** Das Pressenrohr mit der offenen Gewindeseite auf eine feste Unterlage stellen und den Klemmhebel (4) betätigen.  
**⚠ Die Zugstange steht unter Spannung und löst sich mit Druck!** Dann die kompletten Zugstange mit Sicherungsscheibe (5), Manschette (6), Formscheibe (7) und Pressenfeder (8) entnehmen. Dabei löst sich der Klemmhebel (4) aus der Halterung.

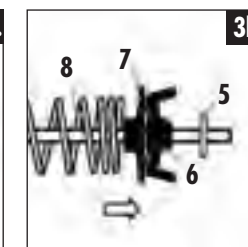
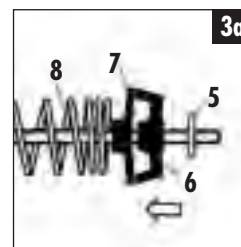

- 3.** Entfernen der Pressenfeder (8), Formscheibe (7) und der Manschette (6) von der Zugstange. Die Sicherungsscheibe (5) bleibt an ihrer Position auf der Zugstange. Jetzt erfolgt das **Umdrehen der Manschette (6)**. Manschette (6), Formscheibe (7) und Pressenfeder (8) wieder auf die Zugstange schieben.

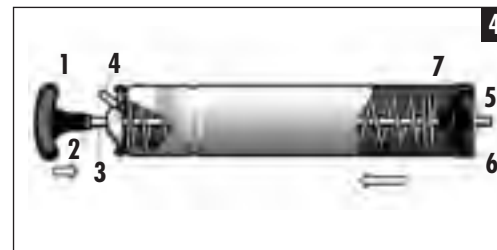

- 4.** Klemmhebel (4) einsetzen. Einführen der montierten Zugstange in das Pressenrohr. Sicherungsmutter und Kreuzgriff wieder auf der Zugstange festschrauben.  
**Das Pressenrohr ist jetzt für die Befüllung mit losem Fett montiert.**

**GB** Instruction for filling the DRP 30 with grease cartridges



**1.** For changing the grease cartridge remove the grease gun barrel.



**2.** Pull back the connecting rod up to the end position



**3.** Insert the grease cartridge.



**4.** Reassemble the gun barrel to the gun head.

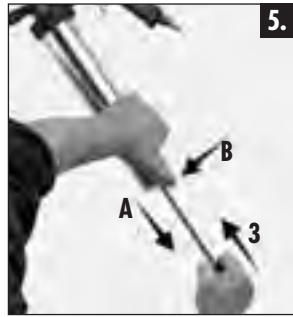

**5.**  
A release pull rod  
B push clamp lever  
C push back the pull rod into the gun barrel.



**6.** Bleeding by pushing the ventilation valve.



**7.** Assembling of accessories (hose or nozzle tube).

**GB** Preparation for filling the DRP 30 with bulk grease



**Attention**  
For filling the grease gun with bulk grease, we recommend to turn the rubber plunger inside the grease gun barrel before. While working on the grease gun barrel according to the following instructions, make sure, that the open, threaded barrel end always point away from either yourself or other persons! In doubt, always consult an expert and follow the safety instruction on [www.umeta.com](http://www.umeta.com) carefully.



**1.** Remove the gun head and pull the connecting rod (3) back until the clamp lever (4) locks and fixes the rod. Then unscrew the grip (1) and the locking nut (2) from the rod.

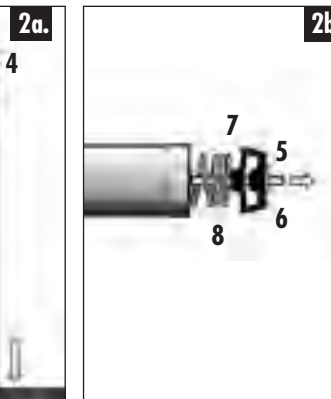

**2.** Place the barrel with the open thread side on a firm base and push the clamp lever (4).  
**⚠ The connecting rod is under tension and releases with pressure!**  
Now remove the interior rod, including locking disc (5), plunger (6), supporter disc (7) and spring (8). In this process, the clamp lever (4) releases out of the bracket.

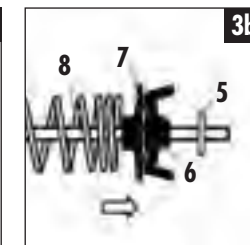
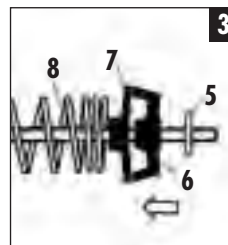

**3.** Remove the spring (8), supporter disc (7) and plunger (6) from the rod. The locking disc (5) remains on its position on the rod. **Now follows the return of the plunger (6).** Push the plunger (6), supporter disc (7) and spring (8) back to the rod.

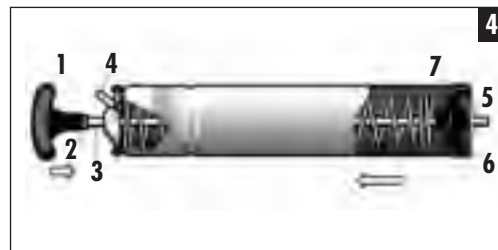

**4.** Refit the clamp lever (4). Insert the assembled connecting rod into the barrel. Screw the locking nut (2) and the grip (1) back onto the rod.  
**Now, the gun barrel is ready for filling with bulk grease.**

## F Instructions pour utilisation de la pompe DRP 30 avec cartouche de graisse



- 1.** Pour changer la cartouche, dévissez la tête



- 2.** Tirez la poignée



- 3.** Introduisez la cartouche dans le corps



- 4.** Revissez la tête

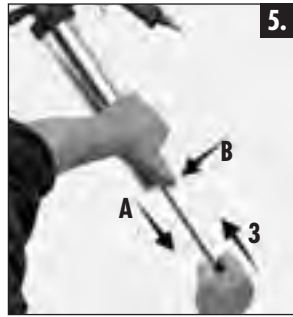

- 5.**  
A Soulagez la tige  
B Appuyez sur l'arrêt de la tige  
C Remplacez la tige dans le corps



- 6.** Purgez l'air



- 7.** Vissez les accessoires

## F Préparation avant utilisation de la pompe DRP 30 avec de la graisse en vrac



### Attention

Il est nécessaire de retourner le manchon placé dans le corps de pompe avant d'utiliser celle-ci avec de la graisse en vrac. N'orientez jamais le corps de pompe vers vous ou d'autres personnes pendant la manipulation ! En cas de doute, faites appel à un spécialiste ! Lisez nos conseils de sécurité sur le site [www.umeta.com](http://www.umeta.com).



- 1.** Dévissez la tête et tirez la tige (3) jusqu'à enclenchement du levier d'arrêt (4) (tige fixée). Dévissez ensuite le croisillon (1) et l'écrou de sécurité (2).

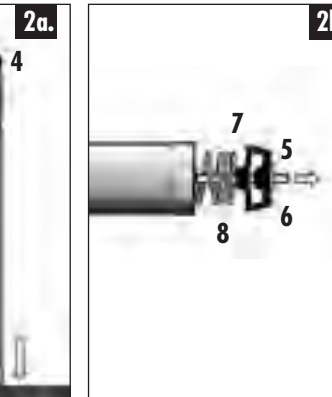

- 2.** Posez le corps de pompe sur une surface dure (filetage en bas) et appuyez sur le levier d'arrêt (4).  
**⚠ La tige est sous pression quand elle se débloque.** Ensuite enlevez la tige complète avec disque de sécurité (5), manchon (6), disque de façonnage (7) et ressort (8). Le levier d'arrêt se détache

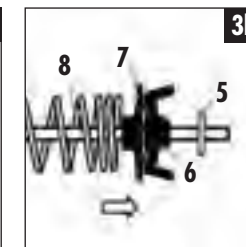
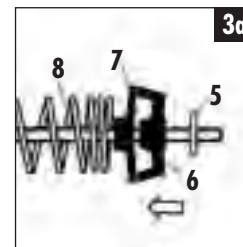

- 3.** Retirez le ressort (8), disque de façonnage (7) et le manchon (6) de la tige. Le disque de sécurité (5) reste en position sur la tige. **Retournez le manchon (6).** Remplacez celui-ci (6) avec le disque de façonnage (7) et le ressort (8) sur la tige.

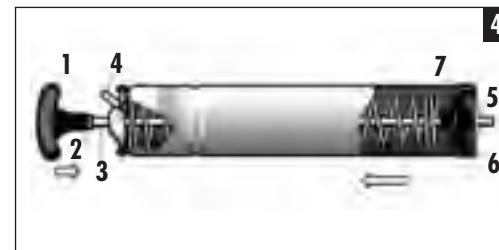

- 4.** Remettez le levier d'arrêt (4) en place. Remplacez la tige complète dans le corps de la pompe. Revissez l'écrou de sécurité et le croisillon sur la tige.  
**Le corps de pompe est maintenant prêt à l'emploi avec de la graisse en vrac.**

## ES Instrucciones para llenar la bomba DRP 30 con cartuchos de grasa



- 1.** Para cambiar el cartucho de grasa quitar el cuerpo de la bomba.



- 2.** Tirar de la varilla de conexión hasta su posición final.



- 3.** Insertar el cartucho de grasa.



- 4.** Volver a colocar el cuerpo de la bomba en su sitio

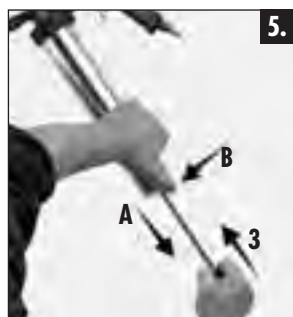

- 5.**  
A Tirar para fuera la varilla  
B Apretar la palanca de fijación  
C Empujar la varilla hacia el interior de la bomba



- 6.** Purgar pulsando la válvula de ventilación.



- 7.** Colocar accesorios (latiguillo o lanza tubular)

## ES Preparación para llenar la bomba DRP 30 con grasa a granel



### Atención

Para llenar la bomba con grasa a granel, se recomienda darle la vuelta al émbolo de goma que se encuentra en el interior del cuerpo de la bomba de engrase. Al realizar esta operación, siguiendo las instrucciones abajo indicadas, asegúrese de no apuntar la parte abierta de la bomba hacia uno mismo o demás personas! En caso de duda, siempre consultar a un experto y seguir las instrucciones de seguridad cuidadosamente en [www.umeta.com](http://www.umeta.com).



- 1.** Quitar la cabeza de la bomba y tirar de la varilla de conexión (3) hasta que la palanca de fijación (4) se bloquee y fije la varilla. Desenroscar la empuñadura de plástico (1) y la tuerca de bloqueo (2) de la varilla.

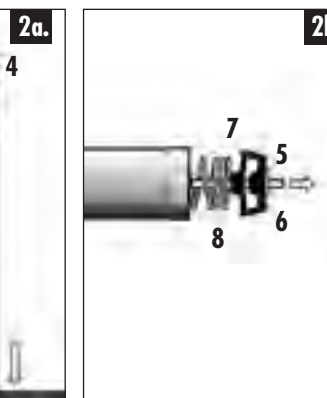

- 2.** Situar la bomba con la parte roscada abierta apoyada en una superficie firme y empujar la palanca de fijación (4).  
**⚠ La varilla de conexión está bajo tensión y se suelta con presión!** Ahora quitar la varilla interior, incluyendo la arandela metálica (5), émbolo de goma (6), disco soporte (7) y muelle (8).

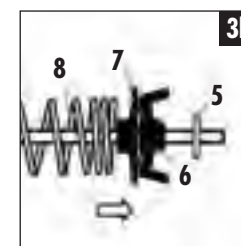
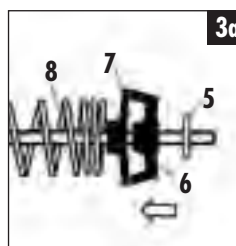

- 3.** Quitar el muelle (8), disco soporte (7) y émbolo de goma (6) de la varilla. La arandela metálica (5) debe permanecer en su posición en la varilla. **Dar la vuelta al émbolo de goma (6).** A continuación volver a colocar el émbolo (6), disco soporte (7) y muelle (8) en la varilla.

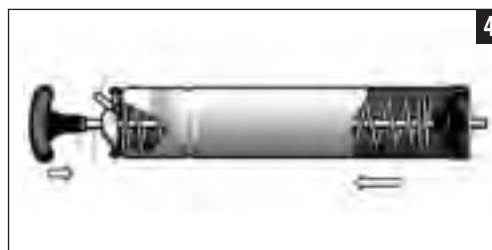

- 4.** Insertar la varilla de conexión ensamblada en el cuerpo de la bomba. Volver a rosca la tuerca de bloqueo (2) y la empuñadura de plástico (1) en la varilla.  
**La bomba ya está lista para su uso con grasa a granel.**

## I Istruzioni per il riempimento del DRP 30 con la cartuccia di lubrificante



- 1.** Per sostituire la cartuccia svitare il tubo dell'ingrassatore

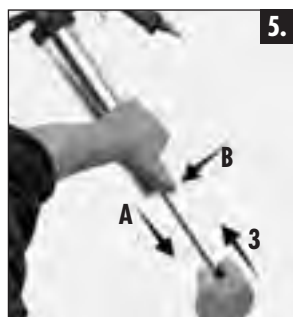

- 5.**  
A Scaricare l'asta di trazione  
B Premere la leva di bloccaggio  
C Spingere l'asta indietro nel tubo dell'ingrassatore



- 2.** Estrarre l'asta di trazione fin nella posizione finale



- 6.** Sfiatare premendo l'apposita valvola



- 3.** Inserire la cartuccia



- 7.** Avvitare gli accessori (tubo con ugello o tubo flessibile)



- 4.** Avvitare il tubo nel gruppo di azionamento

## I Preparativi per il riempimento del DRP 30 con grasso sciolto



### Attenzione

Per il riempimento con grasso sciolto si raccomanda di girare l'anello di tenuta situato all'interno del tubo dell'ingrassatore. Durante l'intera fase di trasformazione non tenere mai il tubo dell'ingrassatore con il lato filettato aperto rivolto verso di sé e verso altre persone! In caso di dubbio rivolgersi sempre a uno specialista e rispettare le nostre avvertenze di sicurezza riportate nel nostro sito all'indirizzo [www.umeta.com](http://www.umeta.com).



- 1.** Togliere la parte superiore dell'ingrassatore ed estrarre l'asta di trazione (3) finché la leva di bloccaggio (4) scatta in posizione, fissando l'asta. Solo successivamente svitare la maniglia a croce (1) e il dado di sicurezza (2) dall'asta.

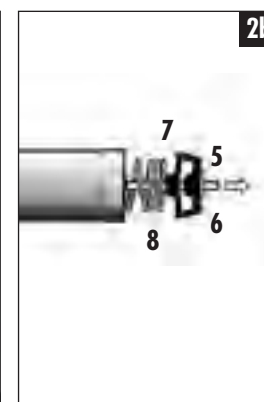

- 2.** Appoggiare il tubo con il lato filettato aperto su una solida base e agire sulla leva di bloccaggio (4).  
**⚠** L'asta di trazione è sotto tensione e si stacca applicando una pressione! Quindi estrarre l'intera asta insieme alla rosetta di sicurezza (5), all'anello di tenuta (6), alla mola sagomata (7) e alla molla (8). Così facendo, la leva di bloccaggio (4) si stacca dal supporto.

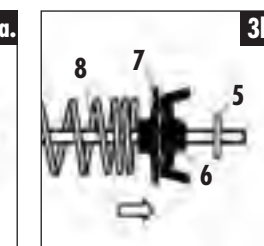
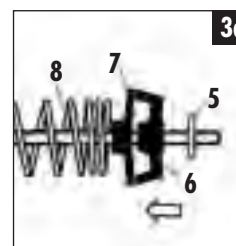

- 3.** Togliere la molla (8), la mola sagomata (7) e l'anello di tenuta (6) dall'asta di trazione. La rosetta di sicurezza (5) rimane nella sua posizione sull'asta. **Quindi girare l'anello di tenuta (6).** Poi spingere nuovamente l'anello di tenuta (6), la mola sagomata (7) e la molla (8) sull'asta.

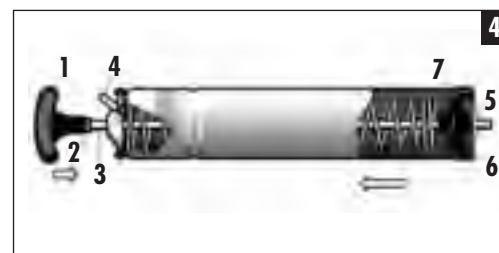

- 4.** Inserire la leva di bloccaggio (4). Infilare l'asta montata nel tubo dell'ingrassatore. Riavvitare il dado di sicurezza e la maniglia a croce sull'asta di trazione. **A questo punto il tubo è montato, pronto per essere riempito con il grasso sciolto.**

## NL Handleiding voor het vullen van de DRP 30 met een vetpatroon



- 1.** Voor het wisselen van de vetpatroon de buis van de perskop draaien.



- 2.** Terugtrekken van de trekstang in eindpositie. De stang blijft automatisch naar achteren staan.



- 3.** Vetpatroon invoeren



- 4.** Buis met patroon weer aan de perskop draaien

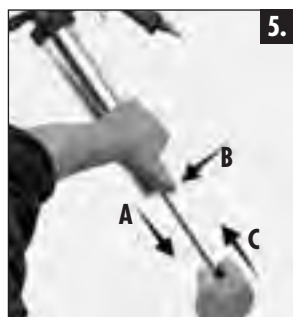

- 5.**  
A Trekstang ontlasten  
B Klemhevel indrukken  
C Trekstang in de buis terugschuiven



- 6.** Ontluchten door het indrukken van het ontluichtingsventiel op de kop van de vetspuit



- 7.** Toebehoor (pijp of slang) vastschroeven

## NL Voorbereiding vulling van de DRP 30 met los vet



### Attentie

Voor het vullen met los vet adviseren wij dringend, de manchet in de buis om te draaien. Houdt u tijdens de gehele ombouw de buis met de open schroefdraad naar beneden, de veer kan dan niet omhoog schieten. Bij twijfel altijd het advies van een specialist vragen en volg beslist onze zekerheidstip op [www.umeta.com](http://www.umeta.com) op.



- 1.** Preskop verwijderen en de trekstang (3) terugtrekken, tot de klemhevel (4) vastzit en de trekstang vasthoudt. Daarna eerst de T-greep (1) en de zekeringsmoer (2) van de trekstang schroeven.

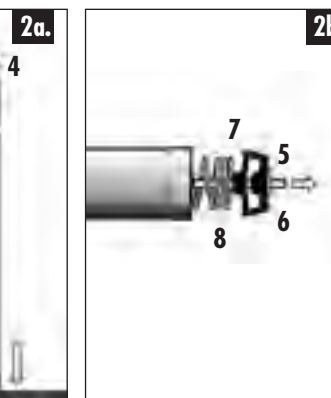

- 2.** De buis met de openkant op een vaste ondergrond zetten en de klemhevel (4) indrukken.

**⚠ De trekstang staat onder spanning en komt door de veerdruk vanzelf los!** Vervolgens de complete trekstang met de zekeringschijf (5), manchet (6), vormschijf (7) en persveer (8) er uithalen. Daarbij komt de klemhevel (4) los uit de houder.

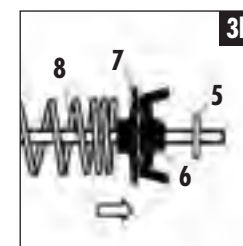
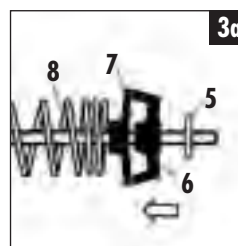

- 3.** Verwijder de persveer (8), vormschijf (7), en de manchet (6) van de trekstang. **Nu kan de manchet (6) worden gedraaid.** Manchet (6), vormschijf (7) en persveer (8) weer terug op de trekstang schuiven.

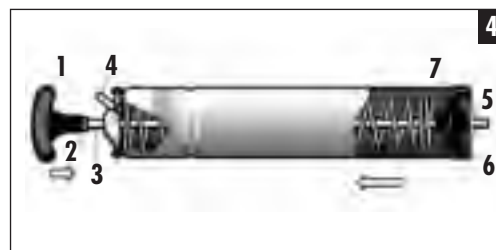

- 4.** Klemhevel (4) weer op zijn plaats houden, waarna de gemonteerde trekstang weer in de buis kan worden ingevoerd. Zekeringsmoer en T-greep weer op de trekstang vastschroeven. **De buis is nu gemonteerd voor het vullen met los vet.**